

GLASS FILLED  
NYLON PLUGS  
INCLUDED

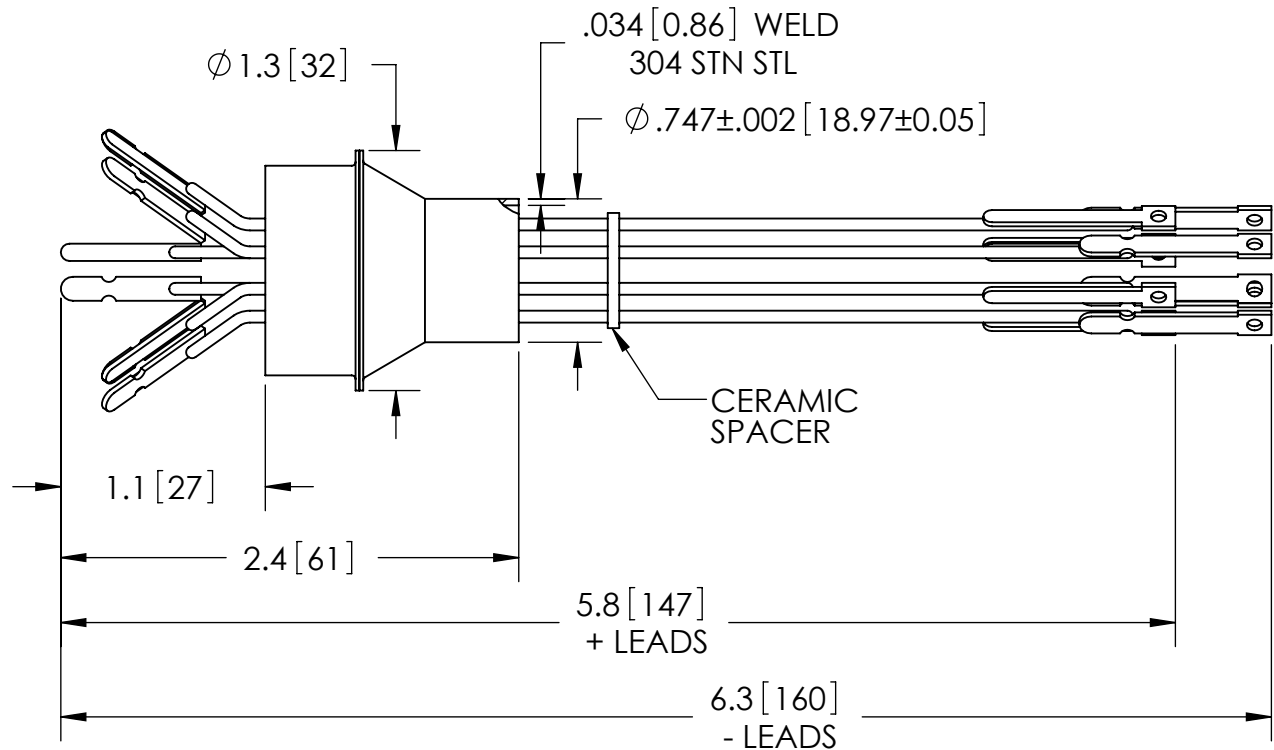
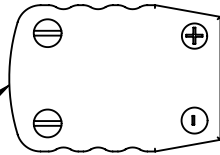

| PART NO.   | CONDUCTOR MATERIAL   | T/C TYPE |
|------------|----------------------|----------|
| FA11719    | CHROMEL / ALUMEL     | K        |
| FA11719-02 | IRON / CONSTANTAN    | J        |
| FA11719-04 | CHROMEL / CONSTANTAN | E        |

| RATINGS                   |                   |
|---------------------------|-------------------|
| CONDUCTOR MATERIAL:       | SEE TABLE AT LEFT |
| T/C TYPE:                 | SEE TABLE AT LEFT |
| PRESSURE:                 | 350 PSIG @ 20°C   |
| TEMPERATURE WITHOUT PLUG: | -269°C TO 450°C   |
| TEMPERATURE WITH PLUG:    | -29°C TO 218°C    |

PROPRIETARY AND CONFIDENTIAL

THE INFORMATION CONTAINED IN THIS DRAWING IS THE SOLE PROPERTY OF SOLID SEALING TECHNOLOGY. ANY REPRODUCTION IN PART OR AS A WHOLE WITHOUT THE WRITTEN PERMISSION OF SOLID SEALING TECHNOLOGY IS PROHIBITED.

THIRD ANGLE PROJECTION



TITLE:

FIVE PAIR T/C FEEDTHROUGH

WWW.SOLIDSEALING.COM



SOLID SEALING TECHNOLOGY, INC.

| REV. | APP'D | DATE       | SCALE 1:1   | DIMENSIONS IN INCHES [mm] | DRAWN     | JM | 1/13/2006  |
|------|-------|------------|-------------|---------------------------|-----------|----|------------|
| B3   | JS    | 06/11/2013 | MPDP0010-ST |                           | ENG APPR. | MH | 05/26/2006 |

PART NO. (SEE TABLE) REV. B

SALES DWG NO. FA11719SL REV. B3

**DIMENSIONS ARE FOR REFERENCE ONLY. UNLESS NOTED, NO TOLERANCES ARE IMPLIED. CONSULT SST TO DISCUSS YOUR SPECIFIC REQUIREMENTS.**