

GLASS FILLED
NYLON PLUGS
INCLUDED

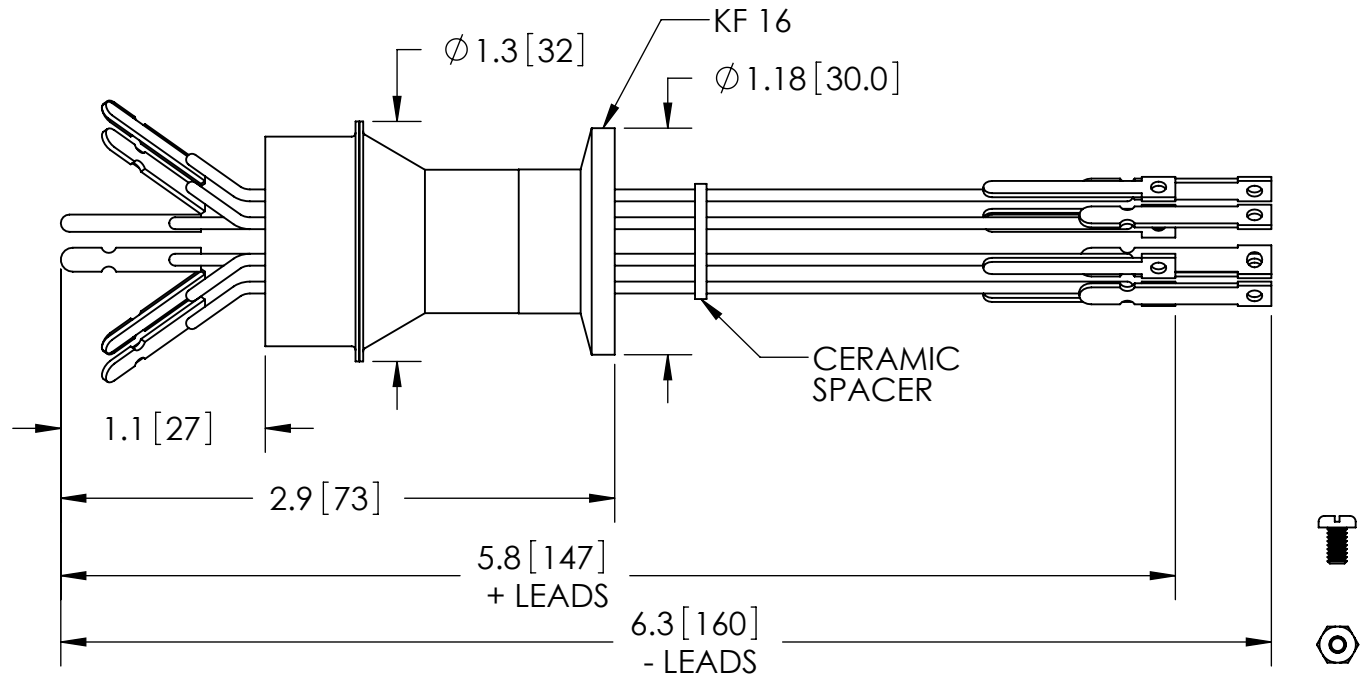
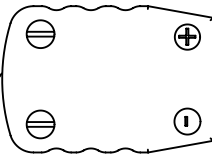

PART NO.	CONDUCTOR MATERIAL	T/C TYPE
FA12115	CHROMEL / ALUMEL	K
FA12115-02	IRON / CONSTANTAN	J
FA12115-04	CHROMEL / CONSTANTAN	E

RATINGS	
CONDUCTOR MATERIAL:	SEE TABLE AT LEFT
T/C TYPE:	SEE TABLE AT LEFT
PRESSURE:	0 PSIG @ 20°C*
TEMPERATURE:	-25°C TO 205°C

*FOR INTERNAL PRESSURE 5 TO 100 PSIG
AN OVERPRESSURE RING IS REQUIRED.

WWW.SOLIDSEALING.COM



SOLID SEALING TECHNOLOGY, INC.

SALES DWG NO. FA12115SL REV. C3

PROPRIETARY AND CONFIDENTIAL

THE INFORMATION CONTAINED IN THIS DRAWING IS THE
SOLE PROPERTY OF SOLID SEALING TECHNOLOGY. ANY
REPRODUCTION IN PART OR AS A WHOLE WITHOUT THE WRITTEN
PERMISSION OF SOLID SEALING TECHNOLOGY IS PROHIBITED.

THIRD ANGLE PROJECTION

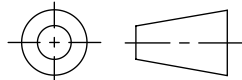

TITLE:

FIVE PAIR T/C FEEDTHROUGH

PART NO. (SEE TABLE) REV. C

REV.	APP'D	DATE	SCALE 1:1	DIMENSIONS IN INCHES [mm]	DRAWN	JM	1/13/2006
C3	JS	06/11/2013	MPDP0014-ST		ENG APPR.	MH	05/26/2006

DIMENSIONS ARE FOR REFERENCE ONLY. UNLESS NOTED, NO TOLERANCES ARE IMPLIED. CONSULT SST TO DISCUSS YOUR SPECIFIC REQUIREMENTS.