

GLASS FILLED
NYLON PLUGS
INCLUDED

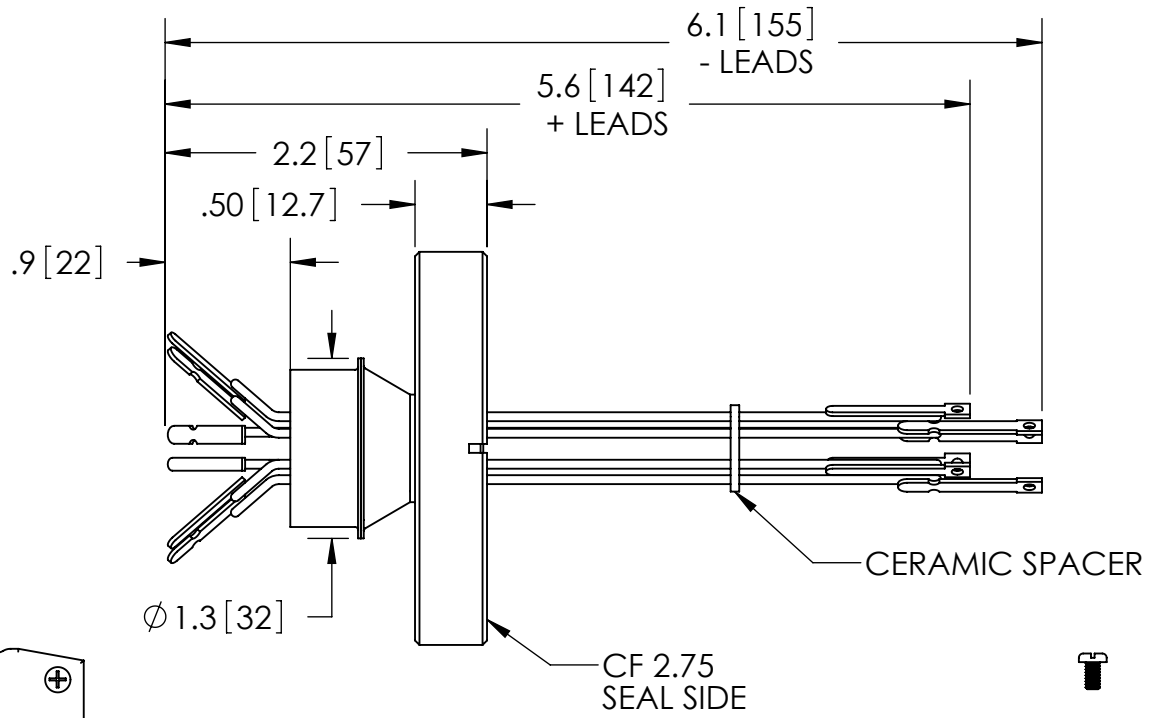
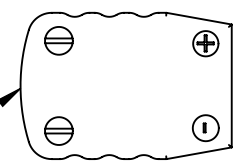

PART NO.	CONDUCTOR MATERIAL	T/C TYPE
FA12328	CHROMEL / ALUMEL	K
FA12328-02	IRON / CONSTANTAN	J
FA12328-04	CHROMEL / CONSTANTAN	E

RATINGS	
CONDUCTOR MATERIAL:	SEE TABLE AT LEFT
T/C TYPE:	SEE TABLE AT LEFT
PRESSURE:	400 PSIG @ 20°C
TEMPERATURE WITHOUT PLUG:	-269°C TO 450°C
TEMPERATURE WITH PLUG:	-29°C TO 218°C

PROPRIETARY AND CONFIDENTIAL
THE INFORMATION CONTAINED IN THIS DRAWING IS THE
SOLE PROPERTY OF SOLID SEALING TECHNOLOGY. ANY
REPRODUCTION IN PART OR AS A WHOLE WITHOUT THE WRITTEN
PERMISSION OF SOLID SEALING TECHNOLOGY IS PROHIBITED.

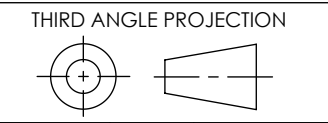

TITLE:
THREE PAIR T/C FEEDTHROUGH

WWW.SOLIDSEALING.COM



REV.	APP'D	DATE	SCALE 3:4	DIMENSIONS IN INCHES [mm]
B1	JS	06/11/2013	MPDP0028-0ST	

DRAWN	JM	1/4/2006
ENG APPR.	MH	05/26/2006

PART NO. (SEE TABLE) REV. B

SOLID SEALING TECHNOLOGY, INC.
SALES DWG NO. FA12328SL REV. B1

DIMENSIONS ARE FOR REFERENCE ONLY. UNLESS NOTED, NO TOLERANCES ARE IMPLIED. CONSULT SST TO DISCUSS YOUR SPECIFIC REQUIREMENTS.