

FOR T/C ASSEMBLIES ONLY:
 + CONDUCTOR LOCATIONS: A,C,E, G, I
 - CONDUCTOR LOCATIONS: B,D,F, H, J

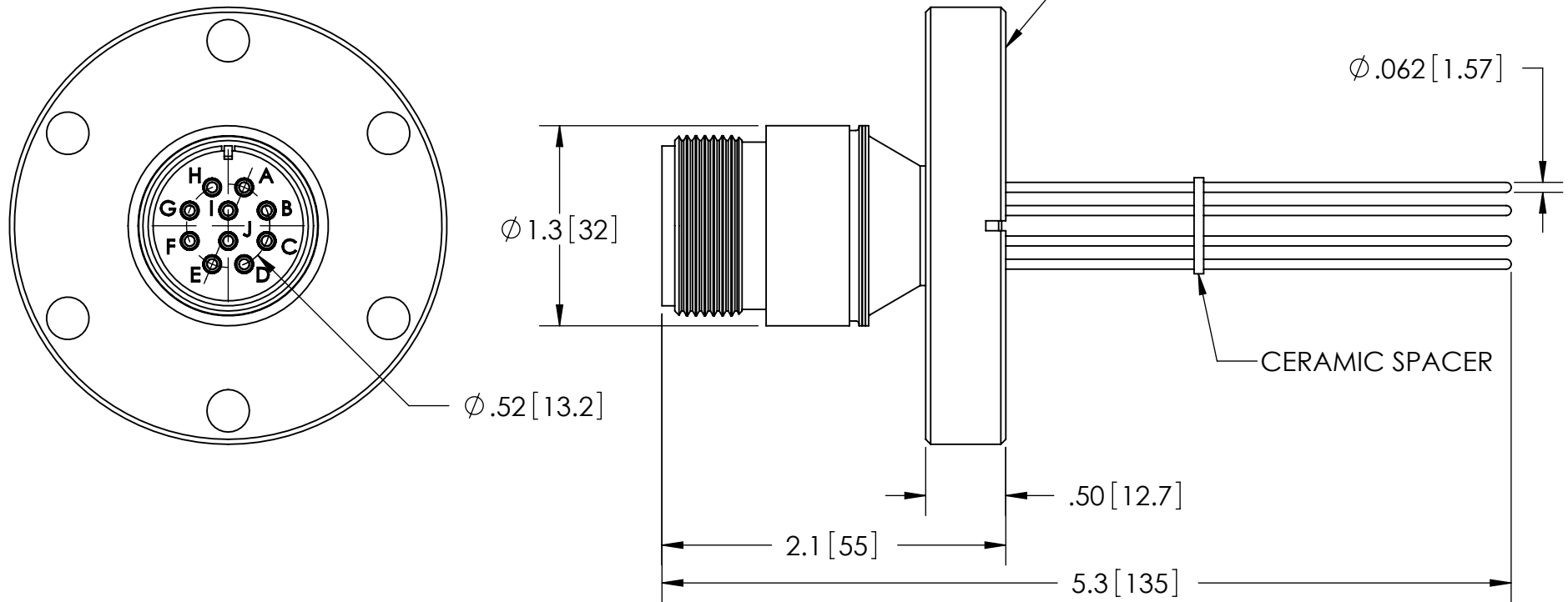

PART NO.	REMARKS	CONDUCTOR MATERIAL	CURRENT	VOLTAGE:	AIR SIDE PLUG INCLUDED
FA13053	POWER	ALUMEL	4.8 AMPS	700V DC	NO
KT13053	POWER	ALUMEL	4.8 AMPS	700V DC	YES
FA13053-02	T/C	CHROMEL/ALUMEL	N/A	N/A	NO
KT13053-02	T/C	CHROMEL/ALUMEL	N/A	N/A	YES

RATINGS	
CONDUCTOR MATERIAL:	SEE TABLE AT LEFT
CURRENT:	SEE TABLE AT LEFT
VOLTAGE:	SEE TABLE AT LEFT
PRESSURE:	500 PSIG @ 20°C
TEMPERATURE WITHOUT PLUGS:	-269°C TO 450°C
TEMPERATURE WITH PLUG:	-55°C TO 125°C

WWW.SOLIDSEALING.COM



SOLID SEALING TECHNOLOGY, INC.

SALES DWG NO. FA13053SL REV. A3

PROPRIETARY AND CONFIDENTIAL

THE INFORMATION CONTAINED IN THIS DRAWING IS THE SOLE PROPERTY OF SOLID SEALING TECHNOLOGY. ANY REPRODUCTION IN PART OR AS A WHOLE WITHOUT THE WRITTEN PERMISSION OF SOLID SEALING TECHNOLOGY IS PROHIBITED.

THIRD ANGLE PROJECTION

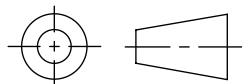

TITLE:

TEN PIN CONNECTOR

PART NO. (SEE TABLE) REV. A

REV.	APP'D	DATE	SCALE 1:1	DIMENSIONS IN INCHES [mm]	DRAWN	JM	12/27/2005
A3	JS	11/26/2012	MPDP0015-1ST		ENG APPR.	MH	04/17/2006

DIMENSIONS ARE FOR REFERENCE ONLY. UNLESS NOTED, NO TOLERANCES ARE IMPLIED. CONSULT SST TO DISCUSS YOUR SPECIFIC REQUIREMENTS.