

GLASS FILLED  
NYLON PLUGS  
INCLUDED

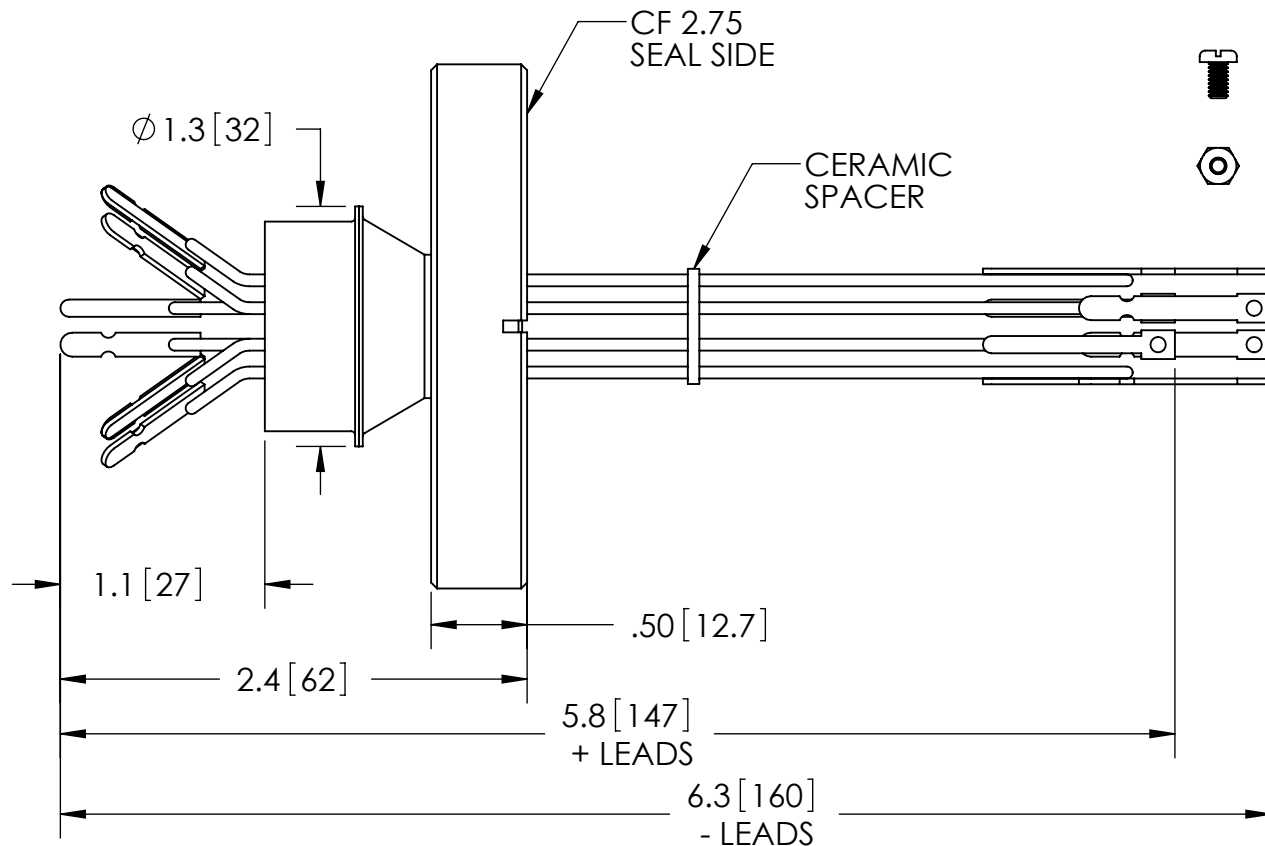
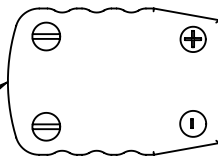

PART NO.	CONDUCTOR MATERIAL	T/C TYPE
FA13184	CHROMEL / ALUMEL	K
FA13184-02	IRON / CONSTANTAN	J
FA13184-04	CHROMEL / CONSTANTAN	E

RATINGS	
CONDUCTOR MATERIAL:	SEE TABLE AT LEFT
T/C TYPE:	SEE TABLE AT LEFT
PRESSURE:	350 PSIG @ 20°C
TEMPERATURE WITHOUT PLUG:	-269°C TO 450°C
TEMPERATURE WITH PLUG:	-29°C TO 218°C

[WWW.SOLIDSEALING.COM](http://WWW.SOLIDSEALING.COM)



**SOLID SEALING TECHNOLOGY, INC.**

SALES DWG NO. FA13184SL REV. C3

PROPRIETARY AND CONFIDENTIAL

THE INFORMATION CONTAINED IN THIS DRAWING IS THE SOLE PROPERTY OF SOLID SEALING TECHNOLOGY. ANY REPRODUCTION IN PART OR AS A WHOLE WITHOUT THE WRITTEN PERMISSION OF SOLID SEALING TECHNOLOGY IS PROHIBITED.

THIRD ANGLE PROJECTION

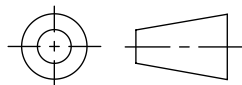

TITLE:

5 PAIR T/C FEEDTHRU

PART NO. (SEE TABLE) REV. C

REV.	APP'D	DATE	SCALE 1:1	DIMENSIONS IN INCHES [mm]	DRAWN	MH	02/27/2006
C3	JS	06/11/2013	MPDP0025-0ST		ENG APPR.	MH	02/27/2006

**DIMENSIONS ARE FOR REFERENCE ONLY. UNLESS NOTED, NO TOLERANCES ARE IMPLIED. CONSULT SST TO DISCUSS YOUR SPECIFIC REQUIREMENTS.**