

GLASS FILLED
NYLON PLUGS
INCLUDED

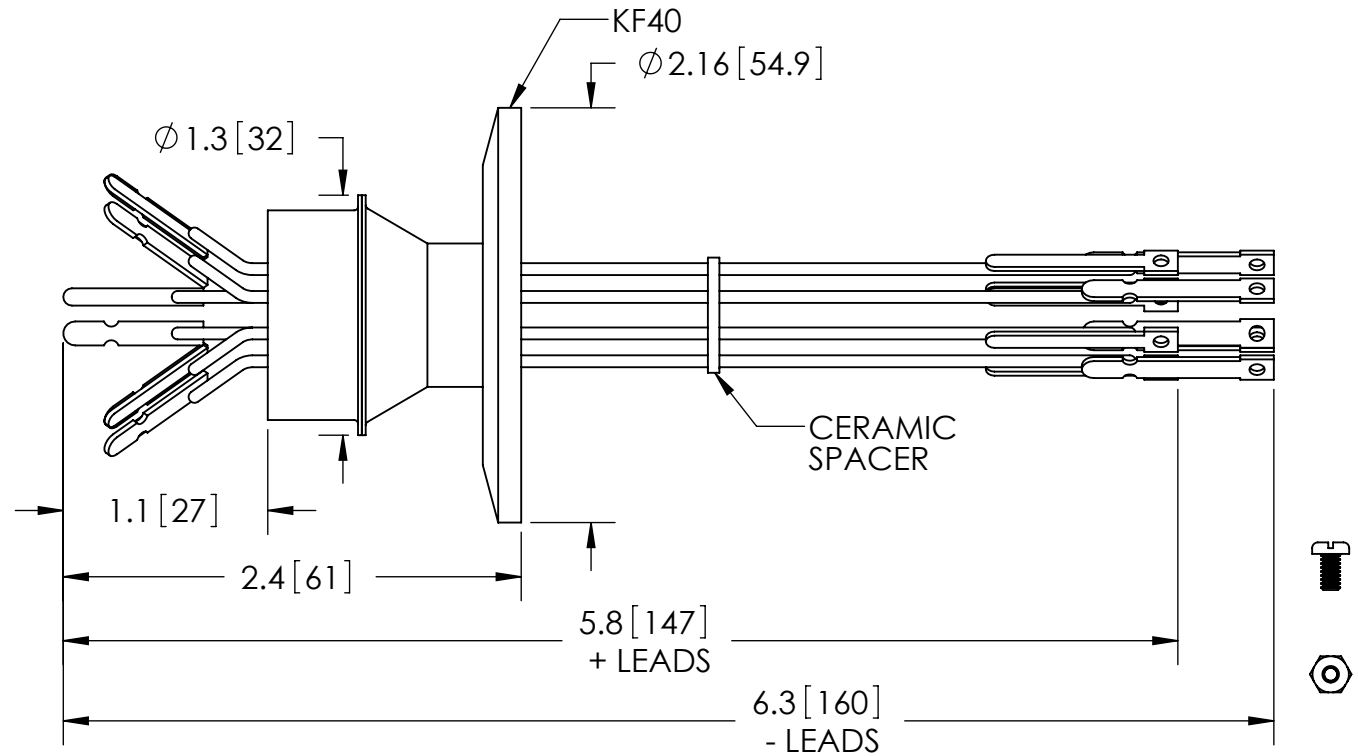
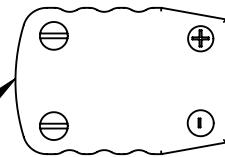

PART NO.	CONDUCTOR MATERIAL	T/C TYPE
FA18423	CHROMEL / ALUMEL	K
FA18423-02	IRON / CONSTANTAN	J
FA18423-04	CHROMEL / CONSTANTAN	E

RATINGS	
CONDUCTOR MATERIAL:	SEE TABLE AT LEFT
T/C TYPE:	SEE TABLE AT LEFT
PRESSURE:	0 PSIG @ 20°C*
TEMPERATURE:	-25°C TO 205°C

*FOR INTERNAL PRESSURE 5 TO 100 PSIG
AN OVERPRESSURE RING IS REQUIRED.

PROPRIETARY AND CONFIDENTIAL

THE INFORMATION CONTAINED IN THIS DRAWING IS THE
SOLE PROPERTY OF SOLID SEALING TECHNOLOGY. ANY
REPRODUCTION IN PART OR AS A WHOLE WITHOUT THE WRITTEN
PERMISSION OF SOLID SEALING TECHNOLOGY IS PROHIBITED.

THIRD ANGLE PROJECTION



TITLE:

FIVE PAIR T/C SPADE TYPE
FEEDTHRU



SOLID SEALING TECHNOLOGY, INC.

REV.	APP'D	DATE	SCALE 1:1	DIMENSIONS IN INCHES [mm]	DRAWN	JS	7/30/2009
A3	JS	06/11/2013	MPDP0014-1ST		ENG APPR.	MH	08/07/2009

PART NO. (SEE TABLE) REV. A

SALES DWG NO. FA18423SL REV. A3

DIMENSIONS ARE FOR REFERENCE ONLY. UNLESS NOTED, NO TOLERANCES ARE IMPLIED. CONSULT SST TO DISCUSS YOUR SPECIFIC REQUIREMENTS.