

NOTE: THE 50 CONDUCTOR CABLE IS MADE BY USING TWO 25 CONDUCTOR CABLES.

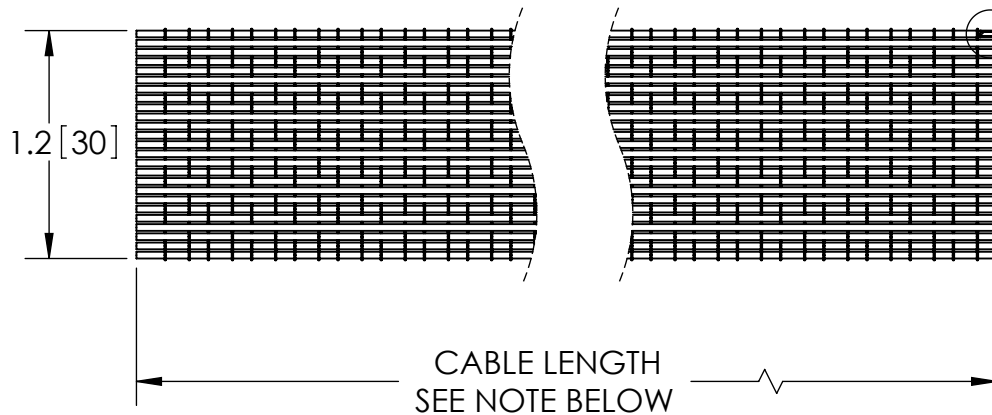
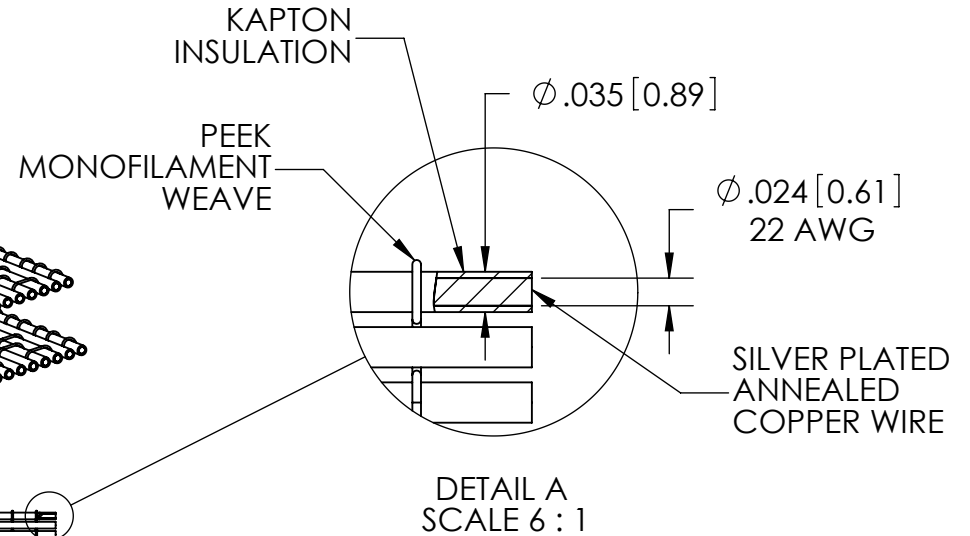
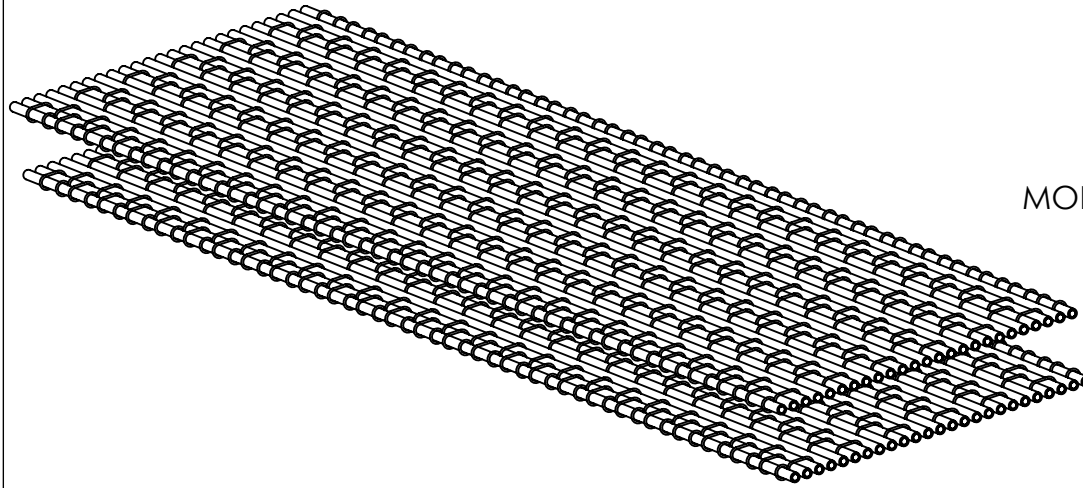

| PERFORMANCE SPECIFICATIONS |                        |
|----------------------------|------------------------|
| # OF CONDUCTORS            | 50                     |
| VOLTAGE:                   | 600V AC/ 850V DC       |
| CURRENT:                   | 5.5 AMPS PER CONDUCTOR |
| TEMPERATURE:               | -55°C TO 200°C         |

CABLE IS AVAILABLE IN ANY LENGTH, PART NUMBER SUFFIX INDICATES LENGTH IN INCHES.

EXAMPLE: FA19822-144 IS A 144 INCH LONG CABLE.

|  |       |            |             |                            |           |                                     |            |   |  |
|--|-------|------------|-------------|----------------------------|-----------|-------------------------------------|------------|---|--|
| PROPRIETARY AND CONFIDENTIAL<br>THE INFORMATION CONTAINED IN THIS DRAWING IS THE SOLE PROPERTY OF SOLID SEALING TECHNOLOGY. ANY REPRODUCTION IN PART OR AS A WHOLE WITHOUT THE WRITTEN PERMISSION OF SOLID SEALING TECHNOLOGY IS PROHIBITED. |       |            |             | THIRD ANGLE PROJECTION<br> |           | TITLE<br><b>22 AWG RIBBON CABLE</b> |            |   |  |
| REV.   | APP'D | DATE       | SCALE 1:1   | DIMENSIONS IN INCHES [mm]  | DRAWN     | JS                                  | 11/19/2008 | PART NO. FA19822 REV. A<br>WWW.SOLIDSEALING.COM |  |
| A3   | JF    | 05/03/2024 | AHDWR004-14 |                            | ENG APPR. | MH                                  | 11/21/2008 |   |  |

**DIMENSIONS ARE FOR REFERENCE ONLY. UNLESS NOTED, NO TOLERANCES ARE IMPLIED. CONSULT SST TO DISCUSS YOUR SPECIFIC REQUIREMENTS.**