

PERFORMANCE SPECIFICATIONS	
.35 dB LOSS PER JUNCTION @ 850 nm TYPICAL, .5 dB MAX (@ROOM TEMPERATURE)	
OPERATING TEMPERATURE: -40°C TO 150°C	
200°C BAKEOUT FOR 1 HOUR	
LEAK RATE <math>< 1 \times 10^{-9}</math> ATM-CC/SEC (He)	

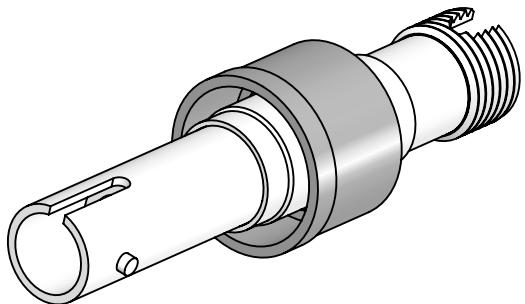

WWW.SOLIDSEALING.COM



SOLID SEALING TECHNOLOGY, INC.

SALES DWG NO. FA35760SL REV. E1

PROPRIETARY AND CONFIDENTIAL

THE INFORMATION CONTAINED IN THIS DRAWING IS THE SOLE PROPERTY OF SOLID SEALING TECHNOLOGY. ANY REPRODUCTION IN PART OR AS A WHOLE WITHOUT THE WRITTEN PERMISSION OF SOLID SEALING TECHNOLOGY IS PROHIBITED.

THIRD ANGLE PROJECTION

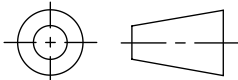

TITLE:

MM FEEDTHROUGH, ST-FC

PART NO. FA35760 REV. E

REV.	APP'D	DATE	SCALE 2:1	DIMENSIONS IN INCHES [mm]	DRAWN	JF	11/27/2018
E1	JF	08/26/2019	FOFDN001-15		ENG APPR.	JF	08/26/2019

DIMENSIONS ARE FOR REFERENCE ONLY. UNLESS NOTED, NO TOLERANCES ARE IMPLIED. CONSULT SST TO DISCUSS YOUR SPECIFIC REQUIREMENTS.