

PERFORMANCE SPECIFICATIONS	
.35 dB LOSS PER JUNCTION @ 850 nm TYPICAL, .5dB MAX (@ ROOM TEMPERATURE)	
OPERATING TEMPERATURE: -40°C TO 150°C	
200°C BAKE OUT FOR 1 HOUR	
LEAK RATE <1 X 10E-9 ATM-CC/SEC (He)	

***SEE SHEET 2 FOR MOUNTING DETAILS**

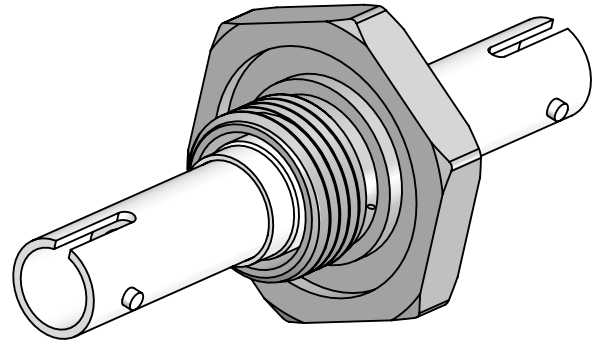

WWW.SOLIDSEALING.COM



SOLID SEALING TECHNOLOGY, INC.

SALES DWG NO. FA38296SL REV. B1

PROPRIETARY AND CONFIDENTIAL THE INFORMATION CONTAINED IN THIS DRAWING IS THE SOLE PROPERTY OF SOLID SEALING TECHNOLOGY. ANY REPRODUCTION IN PART OR AS A WHOLE WITHOUT THE WRITTEN PERMISSION OF SOLID SEALING TECHNOLOGY IS PROHIBITED.				THIRD ANGLE PROJECTION 			TITLE: MM FEEDTHROUGH, ST-ST		
REV.	APP'D	DATE	SCALE 2:1	DIMENSIONS IN INCHES [mm]	DRAWN	JF	12/07/2018	PART NO. FA38296 REV. B	
B1	JF	11/26/2019	FOFDN001-28		ENG APPR.	JF	12/11/2018		

DIMENSIONS ARE FOR REFERENCE ONLY. UNLESS NOTED, NO TOLERANCES ARE IMPLIED. CONSULT SST TO DISCUSS YOUR SPECIFIC REQUIREMENTS.

JAM NUT PANEL MOUNTING CONFIGURATION

.093 [2.35] MAX PANEL THICKNESS

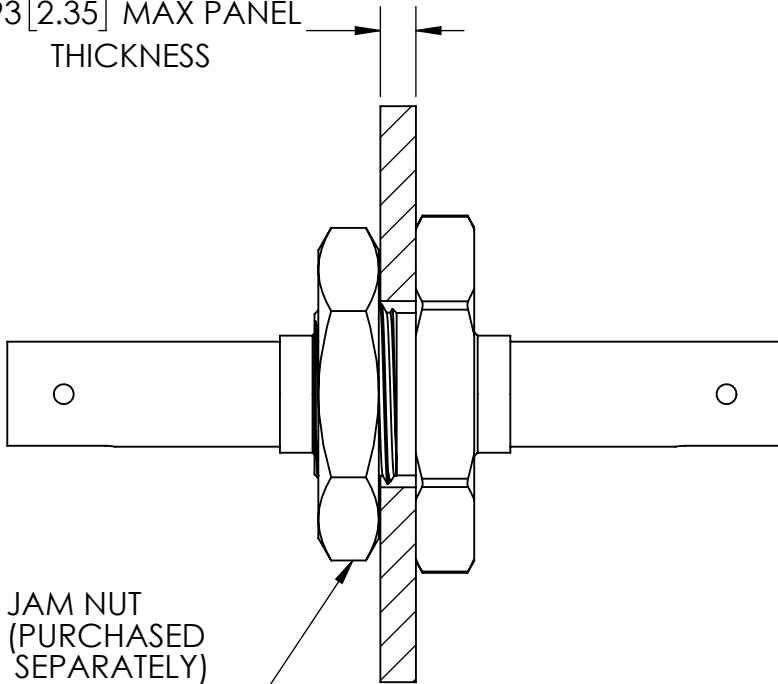

JAM NUT
(PURCHASED
SEPARATELY)
SEE FP38340

THREADED PANEL MOUNTING CONFIGURATION

.25 [6.35] TO .75 [19.05]
RECOMMENDED
PANEL THICKNESS

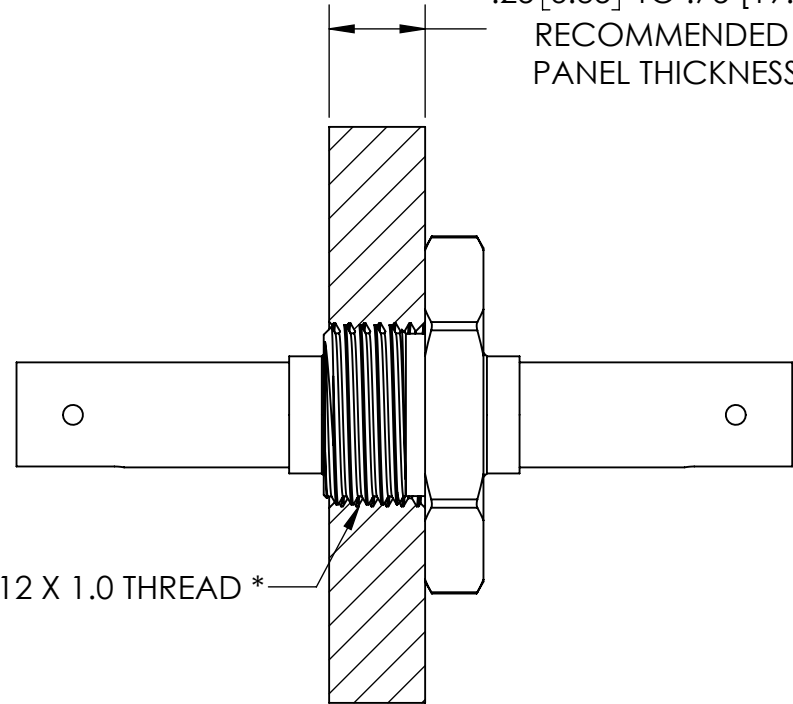

M12 X 1.0 THREAD *

* IF THREAD IS NOT TAPPED THROUGH, ITS DEPTH MUST BE AT LEAST .264 [6.71]

PROPRIETARY AND CONFIDENTIAL

THE INFORMATION CONTAINED IN THIS DRAWING IS THE SOLE PROPERTY OF SOLID SEALING TECHNOLOGY. ANY REPRODUCTION IN PART OR AS A WHOLE WITHOUT THE WRITTEN PERMISSION OF SOLID SEALING TECHNOLOGY IS PROHIBITED.

THIRD ANGLE PROJECTION

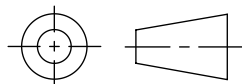

TITLE:

MM FEEDTHROUGH, ST-ST

WWW.SOLIDSEALING.COM



SOLID SEALING TECHNOLOGY, INC.

REV.	APP'D	DATE	SCALE 2:1	DIMENSIONS IN INCHES [mm]	DRAWN	JF	12/07/2018
B1	JF	11/26/2019	FDN001-28_MOUNTING		ENG APPR.	JF	12/11/2018

PART NO. FA38296 REV. B

SALES DWG NO. FA38296SL REV. B1

DIMENSIONS ARE FOR REFERENCE ONLY. UNLESS NOTED, NO TOLERANCES ARE IMPLIED. CONSULT SST TO DISCUSS YOUR SPECIFIC REQUIREMENTS.