

PERFORMANCE SPECIFICATIONS	
.3 dB LOSS PER JUNCTION @ 1550 nm TYPICAL, .45dB MAX (@ ROOM TEMPERATURE)	
OPERATING TEMPERATURE: -40°C TO 150°C	
LEAK RATE <1 X 10E-9 ATM-CC/SEC (He)	

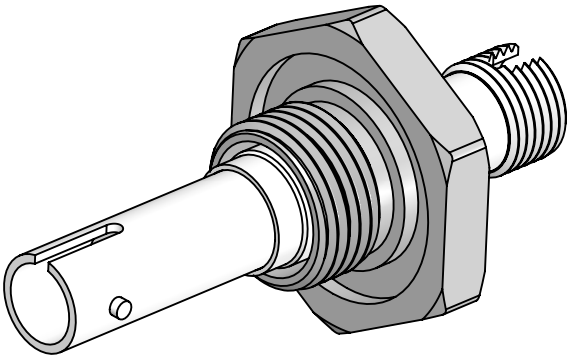

***SEE SHEET 2 FOR MOUNTING DETAILS**

PROPRIETARY AND CONFIDENTIAL THE INFORMATION CONTAINED IN THIS DRAWING IS THE SOLE PROPERTY OF SOLID SEALING TECHNOLOGY. ANY REPRODUCTION IN PART OR AS A WHOLE WITHOUT THE WRITTEN PERMISSION OF SOLID SEALING TECHNOLOGY IS PROHIBITED.				THIRD ANGLE PROJECTION 		TITLE: SM FEEDTHROUGH, ST-FC		WWW.SOLIDSEALING.COM 	
REV.	APP'D	DATE	SCALE 2:1	DIMENSIONS IN INCHES [mm]	DRAWN	JF	11/02/2018	PART NO. FA38322 REV. A	
A2	JF	03/05/2019	fofdn003-21		ENG APPR.	JF	11/02/2018		

DIMENSIONS ARE FOR REFERENCE ONLY. UNLESS NOTED, NO TOLERANCES ARE IMPLIED. CONSULT SST TO DISCUSS YOUR SPECIFIC REQUIREMENTS.

JAM NUT PANEL MOUNTING CONFIGURATION

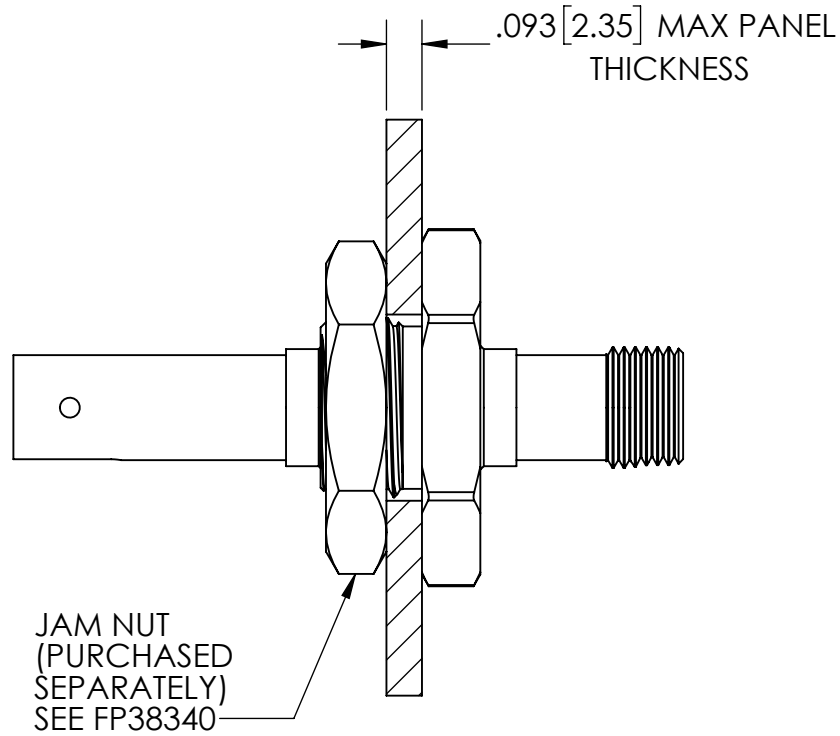

THREADED PANEL MOUNTING CONFIGURATION

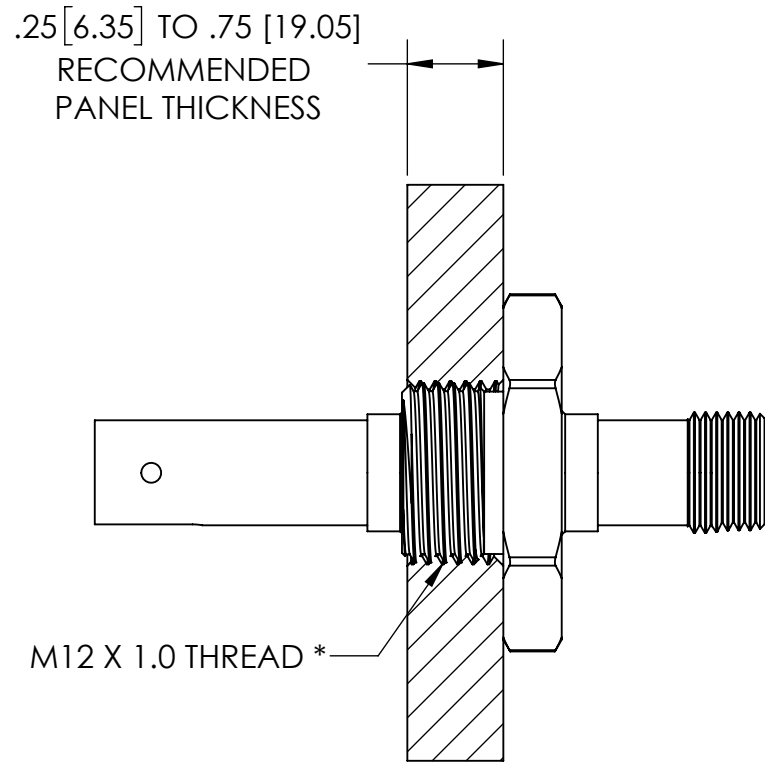

*IF THREAD IS NOT TAPPED THROUGH, IT'S DEPTH MUST BE AT LEAST .264" [6.71].

WWW.SOLIDSEALING.COM



SOLID SEALING TECHNOLOGY, INC.

SALES DWG NO. FA38322SL REV. A2

PROPRIETARY AND CONFIDENTIAL

THE INFORMATION CONTAINED IN THIS DRAWING IS THE SOLE PROPERTY OF SOLID SEALING TECHNOLOGY. ANY REPRODUCTION IN PART OR AS A WHOLE WITHOUT THE WRITTEN PERMISSION OF SOLID SEALING TECHNOLOGY IS PROHIBITED.

THIRD ANGLE PROJECTION

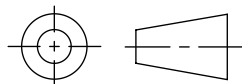

TITLE:

SM FEEDTHROUGH, ST-FC

PART NO. FA38322 REV. A

REV.	APP'D	DATE	SCALE 1:1	DIMENSIONS IN	DRAWN	JF	11/02/2018
A2	JF	03/05/2019	1/2	INCHES [mm]	ENG APPR.	JF	11/02/2018

DIMENSIONS ARE FOR REFERENCE ONLY. UNLESS NOTED, NO TOLERANCES ARE IMPLIED. CONSULT SST TO DISCUSS YOUR SPECIFIC REQUIREMENTS.