

| PERFORMANCE SPECIFICATIONS |
|--|
| .3 dB LOSS PER JUNCTION @ 1550 nm TYPICAL, .45dB MAX (@ ROOM TEMPERATURE) |
| OPERATING TEMPERATURE: -40°C TO 150°C |
| LEAK RATE <1 X 10E-9 ATM-CC/SEC (He) |

***SEE SHEET 2 FOR MOUNTING DETAILS**

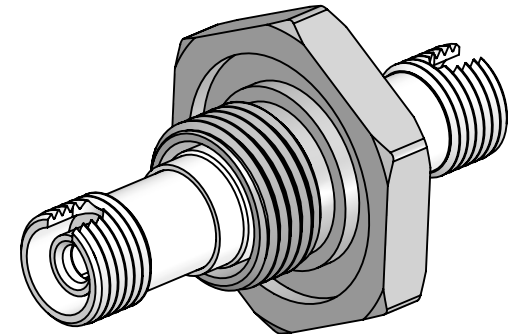

WWW.SOLIDSEALING.COM



SOLID SEALING TECHNOLOGY, INC.

SALES DWG NO. FA38323SL REV. A2

PROPRIETARY AND CONFIDENTIAL

THE INFORMATION CONTAINED IN THIS DRAWING IS THE SOLE PROPERTY OF SOLID SEALING TECHNOLOGY. ANY REPRODUCTION IN PART OR AS A WHOLE WITHOUT THE WRITTEN PERMISSION OF SOLID SEALING TECHNOLOGY IS PROHIBITED.

THIRD ANGLE PROJECTION



TITLE:

SM FEEDTHROUGH, FC-FC

| REV. | APP'D | DATE | SCALE 2:1 | DIMENSIONS IN INCHES [mm] | DRAWN | HJ | 10/31/2018 |
|------|-------|------------|-------------|---------------------------|-----------|----|------------|
| A2 | JF | 03/06/2019 | fofdn003-22 | | ENG APPR. | JF | 11/01/2018 |

PART NO. FA38323 REV. A

DIMENSIONS ARE FOR REFERENCE ONLY. UNLESS NOTED, NO TOLERANCES ARE IMPLIED. CONSULT SST TO DISCUSS YOUR SPECIFIC REQUIREMENTS.

JAM NUT PANEL MOUNTING CONFIGURATION

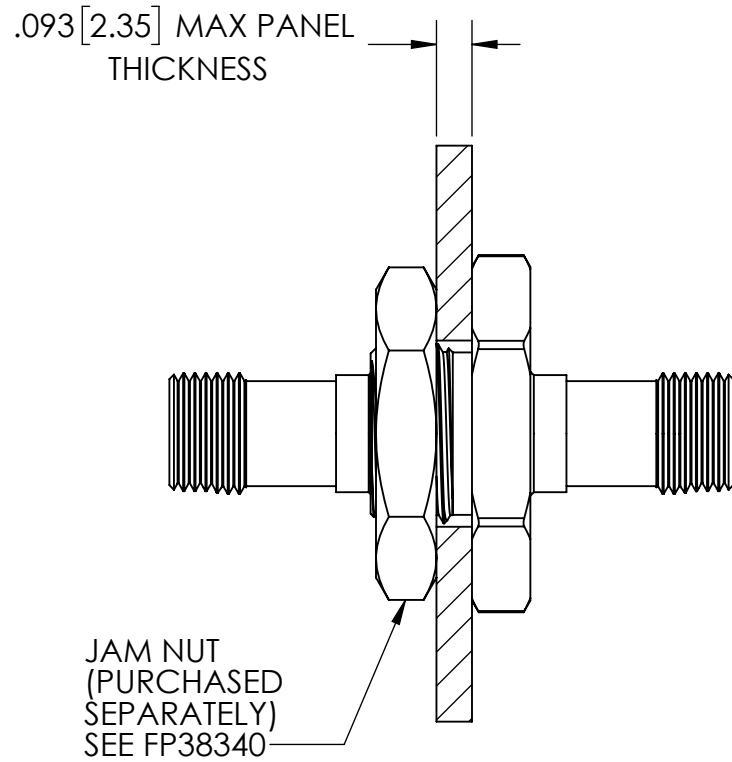

THREADED PANEL MOUNTING CONFIGURATION

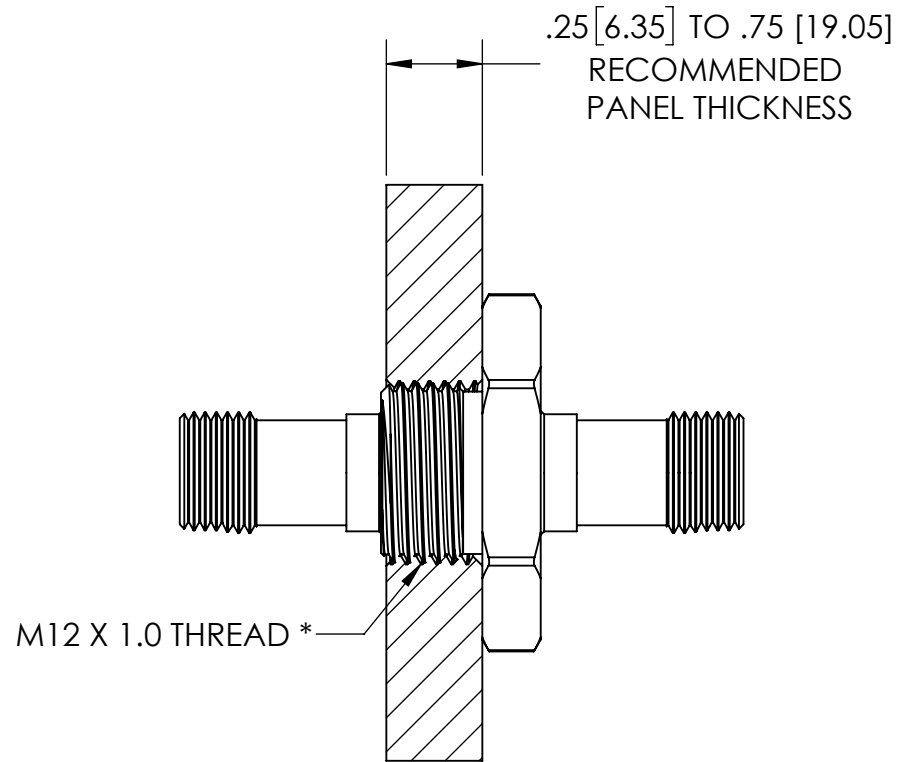

*IF THREAD IS NOT TAPPED THROUGH, IT'S DEPTH MUST BE AT LEAST .264" [6.71].

PROPRIETARY AND CONFIDENTIAL

THE INFORMATION CONTAINED IN THIS DRAWING IS THE SOLE PROPERTY OF SOLID SEALING TECHNOLOGY. ANY REPRODUCTION IN PART OR AS A WHOLE WITHOUT THE WRITTEN PERMISSION OF SOLID SEALING TECHNOLOGY IS PROHIBITED.

THIRD ANGLE PROJECTION

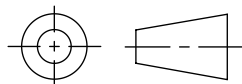

TITLE:

SM FEEDTHROUGH, FC-FC

WWW.SOLIDSEALING.COM



SOLID SEALING TECHNOLOGY, INC.

| REV. | APP'D | DATE | SCALE 1:1 | DIMENSIONS IN INCHES [mm] | DRAWN | HJ | 10/31/2018 |
|------|-------|------------|-----------|---------------------------|-----------|----|------------|
| A2 | JF | 03/06/2019 | 1:1 | 1/2 | ENG APPR. | JF | 11/01/2018 |

PART NO. FA38323 REV. A

SALES DWG NO. FA38323SL REV. A2

DIMENSIONS ARE FOR REFERENCE ONLY. UNLESS NOTED, NO TOLERANCES ARE IMPLIED. CONSULT SST TO DISCUSS YOUR SPECIFIC REQUIREMENTS.