

PERFORMANCE SPECIFICATIONS	
.3 dB LOSS PER JUNCTION @ 1550 nm TYPICAL, .45 dB MAX (@ ROOM TEMPERATURE)	
OPERATING TEMPERATURE: -40°C TO 150°C	
LEAK RATE <1 X 10E-9 ATM-CC/SEC (He)	

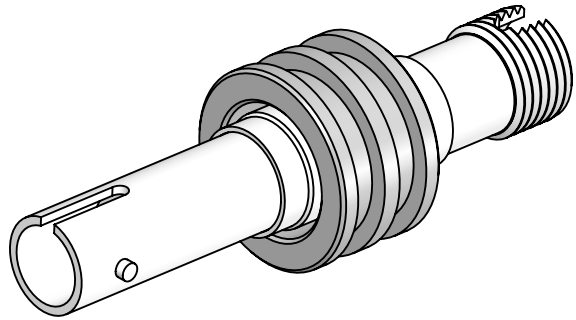

**\*SEE SHEET 2 FOR INSTALLATION AND MOUNTING DETAILS**

PROPRIETARY AND CONFIDENTIAL THE INFORMATION CONTAINED IN THIS DRAWING IS THE SOLE PROPERTY OF SOLID SEALING TECHNOLOGY. ANY REPRODUCTION IN PART OR AS A WHOLE WITHOUT THE WRITTEN PERMISSION OF SOLID SEALING TECHNOLOGY IS PROHIBITED.				THIRD ANGLE PROJECTION 		TITLE: SM FEEDTHROUGH, ST-FC		<a href="http://WWW.SOLIDSEALING.COM">WWW.SOLIDSEALING.COM</a> 	
REV. APP'D DATE SCALE 2:1 DIMENSIONS IN INCHES [mm]	DRAWN JF 11/07/2018	ENG APPR. JF 11/07/2018	PART NO. FA38328 REV. A				SOLID SEALING TECHNOLOGY, INC. SALES DWG NO. FA38328SL REV. A3		

**DIMENSIONS ARE FOR REFERENCE ONLY. UNLESS NOTED, NO TOLERANCES ARE IMPLIED. CONSULT SST TO DISCUSS YOUR SPECIFIC REQUIREMENTS.**

### INSTALLED VIEW

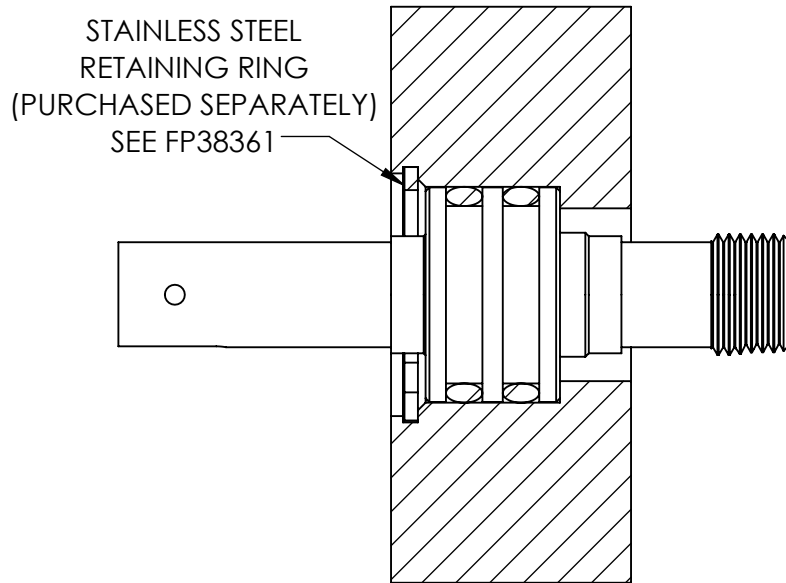

### MOUNTING DIMENSIONS

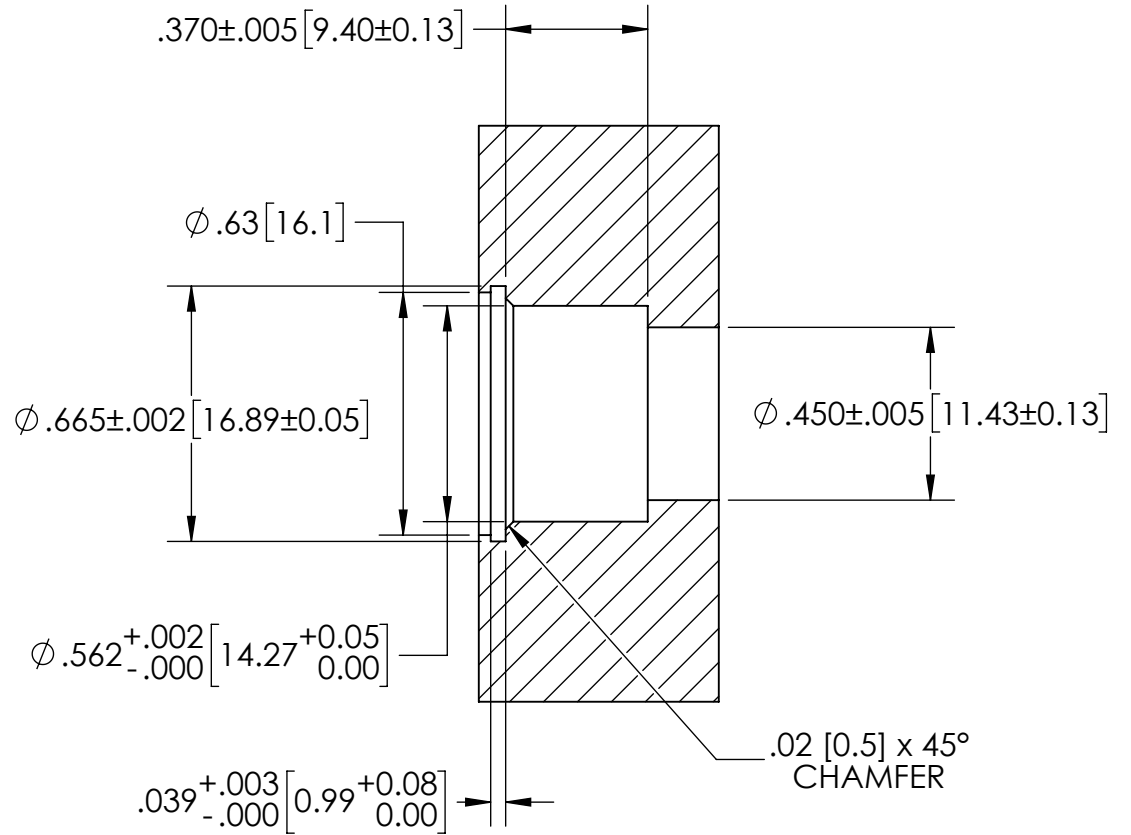

PROPRIETARY AND CONFIDENTIAL

THE INFORMATION CONTAINED IN THIS DRAWING IS THE SOLE PROPERTY OF SOLID SEALING TECHNOLOGY. ANY REPRODUCTION IN PART OR AS A WHOLE WITHOUT THE WRITTEN PERMISSION OF SOLID SEALING TECHNOLOGY IS PROHIBITED.

THIRD ANGLE PROJECTION

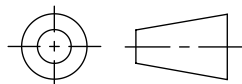

TITLE:

SM FEEDTHROUGH, ST-FC

[WWW.SOLIDSEALING.COM](http://WWW.SOLIDSEALING.COM)



SOLID SEALING TECHNOLOGY, INC.

REV.	APP'D	DATE	SCALE 2:1	DIMENSIONS IN INCHES [mm]	DRAWN	JF	11/07/2018
A3	JF	03/12/2019	dh003-27_MOUNTING		ENG APPR.	JF	11/07/2018

PART NO. FA38328 REV. A

SALES DWG NO. FA38328SL REV. A3

**DIMENSIONS ARE FOR REFERENCE ONLY. UNLESS NOTED, NO TOLERANCES ARE IMPLIED. CONSULT SST TO DISCUSS YOUR SPECIFIC REQUIREMENTS.**