

PERFORMANCE SPECIFICATIONS

.3 dB LOSS PER JUNCTION @ 1550 nm TYPICAL,
.45 dB MAX (@ ROOM TEMPERATURE)

OPERATING TEMPERATURE: -40°C TO 150°C

LEAK RATE <1 X 10E-9 ATM-CC/SEC (He)

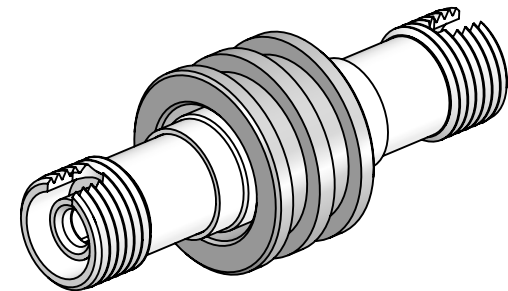

***SEE SHEET 2 FOR INSTALLATION AND MOUNTING DETAILS**

WWW.SOLIDSEALING.COM



SOLID SEALING TECHNOLOGY, INC.

SALES DWG NO. FA38329SL REV. A3

PROPRIETARY AND CONFIDENTIAL

THE INFORMATION CONTAINED IN THIS DRAWING IS THE SOLE PROPERTY OF SOLID SEALING TECHNOLOGY. ANY REPRODUCTION IN PART OR AS A WHOLE WITHOUT THE WRITTEN PERMISSION OF SOLID SEALING TECHNOLOGY IS PROHIBITED.

THIRD ANGLE PROJECTION

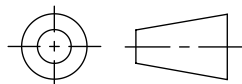

TITLE:

SM FEEDTHROUGH, FC-FC

PART NO. FA38329 REV. A

REV.	APP'D	DATE	SCALE 2:1	DIMENSIONS IN INCHES [mm]	DRAWN	JF	11/12/2018
A3	JF	03/12/2019	fofd003-28		ENG APPR.	JF	11/12/2018

DIMENSIONS ARE FOR REFERENCE ONLY. UNLESS NOTED, NO TOLERANCES ARE IMPLIED. CONSULT SST TO DISCUSS YOUR SPECIFIC REQUIREMENTS.

INSTALLED VIEW

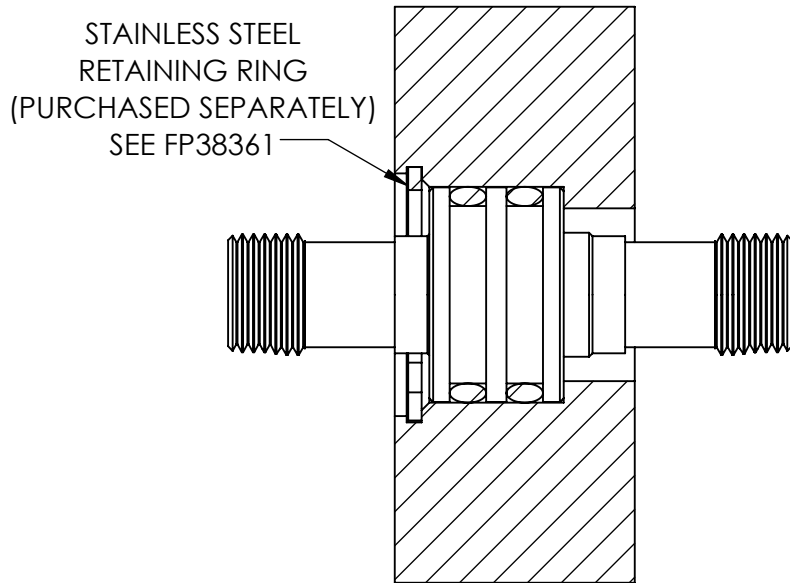

MOUNTING DIMENSIONS

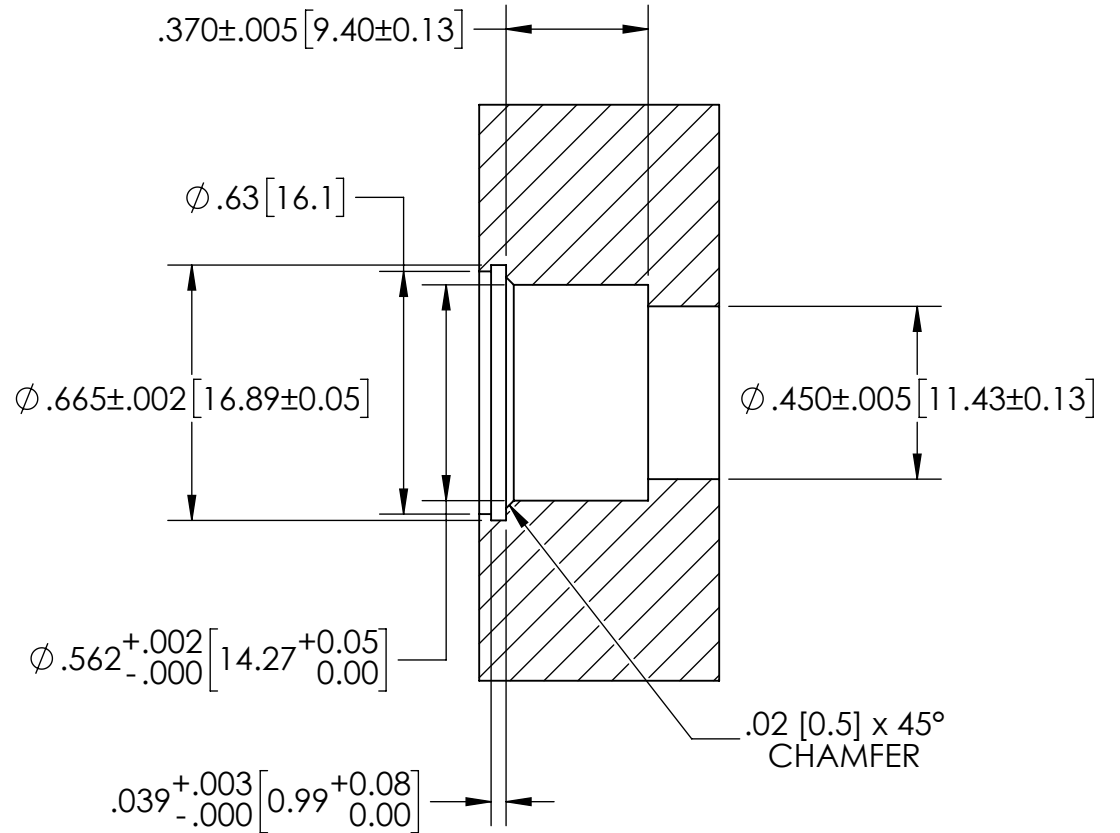

WWW.SOLIDSEALING.COM



SOLID SEALING TECHNOLOGY, INC.

SALES DWG NO. FA38329SL REV. A3

PROPRIETARY AND CONFIDENTIAL

THE INFORMATION CONTAINED IN THIS DRAWING IS THE SOLE PROPERTY OF SOLID SEALING TECHNOLOGY. ANY REPRODUCTION IN PART OR AS A WHOLE WITHOUT THE WRITTEN PERMISSION OF SOLID SEALING TECHNOLOGY IS PROHIBITED.

THIRD ANGLE PROJECTION

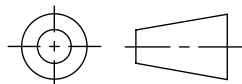

TITLE:

SM FEEDTHROUGH, FC-FC

PART NO. FA38329 REV. A

REV.	APP'D	DATE	SCALE 2:1	DIMENSIONS IN INCHES [mm]	DRAWN	JF	11/12/2018
A3	JF	03/12/2019	FA38329_MOUNTING		ENG APPR.	JF	11/12/2018

DIMENSIONS ARE FOR REFERENCE ONLY. UNLESS NOTED, NO TOLERANCES ARE IMPLIED. CONSULT SST TO DISCUSS YOUR SPECIFIC REQUIREMENTS.