

PERFORMANCE SPECIFICATIONS

.3 dB LOSS PER JUNCTION @ 1550 nm TYPICAL,
.45 dB MAX (@ ROOM TEMPERATURE)

OPERATING TEMPERATURE: -40°C TO 150°C

LEAK RATE <math>< 1 \times 10^{-9}</math> ATM-CC/SEC (He)

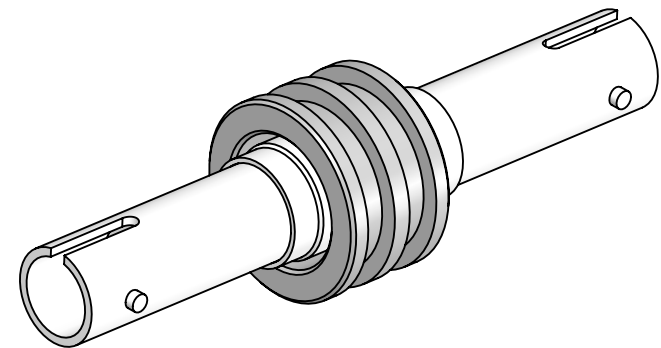

***SEE SHEET 2 FOR INSTALLATION AND MOUNTING DETAILS**

PROPRIETARY AND CONFIDENTIAL THE INFORMATION CONTAINED IN THIS DRAWING IS THE SOLE PROPERTY OF SOLID SEALING TECHNOLOGY. ANY REPRODUCTION IN PART OR AS A WHOLE WITHOUT THE WRITTEN PERMISSION OF SOLID SEALING TECHNOLOGY IS PROHIBITED.				THIRD ANGLE PROJECTION 		TITLE: SM FEEDTHROUGH, ST-ST		WWW.SOLIDSEALING.COM 	
REV.	APP'D	DATE	SCALE 2:1	DIMENSIONS IN INCHES [mm]	DRAWN	JF	11/26/2018	PART NO. FA38330 REV. A	
A3	JF	03/12/2019	fofdn003-29		ENG APPR.	JF	11/26/2018		

DIMENSIONS ARE FOR REFERENCE ONLY. UNLESS NOTED, NO TOLERANCES ARE IMPLIED. CONSULT SST TO DISCUSS YOUR SPECIFIC REQUIREMENTS.

INSTALLED VIEW

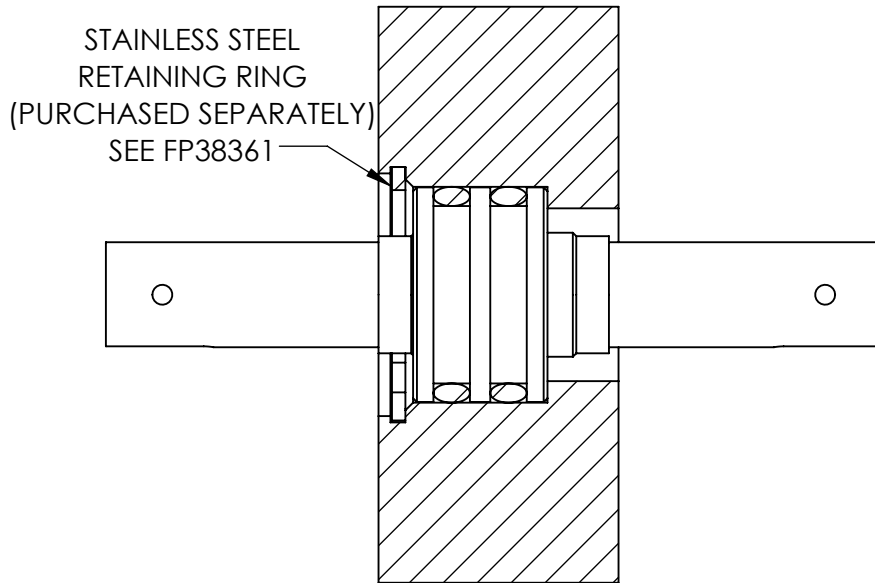

MOUNTING DIMENSIONS

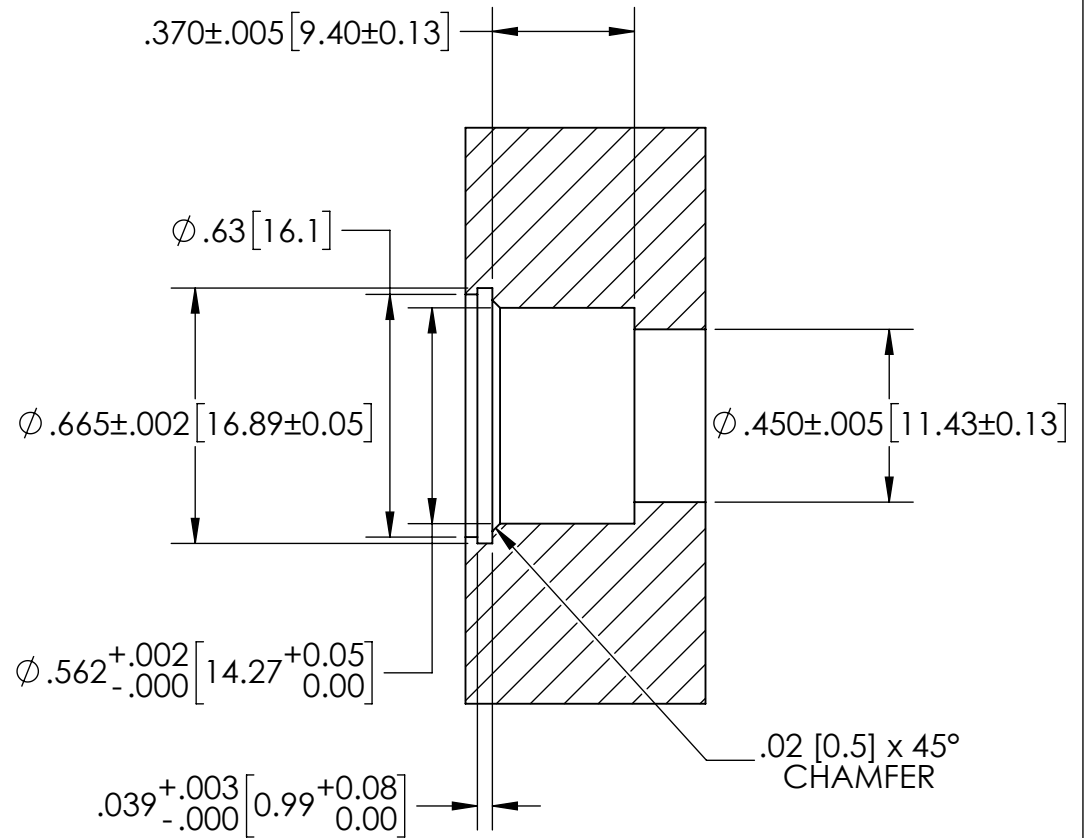

PROPRIETARY AND CONFIDENTIAL

THE INFORMATION CONTAINED IN THIS DRAWING IS THE SOLE PROPERTY OF SOLID SEALING TECHNOLOGY. ANY REPRODUCTION IN PART OR AS A WHOLE WITHOUT THE WRITTEN PERMISSION OF SOLID SEALING TECHNOLOGY IS PROHIBITED.

THIRD ANGLE PROJECTION

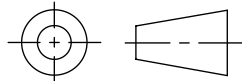

TITLE:

SM FEEDTHROUGH, ST-ST

WWW.SOLIDSEALING.COM



SOLID SEALING TECHNOLOGY, INC.

REV.	APP'D	DATE	SCALE 2:1	DIMENSIONS IN INCHES [mm]	DRAWN	JF	11/26/2018
A3	JF	03/12/2019	FA38330_29_MOUNTING		ENG APPR.	JF	11/26/2018

PART NO. FA38330 REV. A

SALES DWG NO. FA38330SL REV. A3

DIMENSIONS ARE FOR REFERENCE ONLY. UNLESS NOTED, NO TOLERANCES ARE IMPLIED. CONSULT SST TO DISCUSS YOUR SPECIFIC REQUIREMENTS.