

Ø .47 [12.0]
BOTH SIDES

GOLD PLATED COPPER ALLOY
CRIMP PIN CONTACTS

.477 [12.12]
4PLS

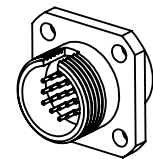

SCALE 1:1

REFER TO INSTRUCTION SHEET "NS41656" FOR ASSEMBLY INSTRUCTIONS

MATES WITH
FA41232

4X Ø .095 [2.41]

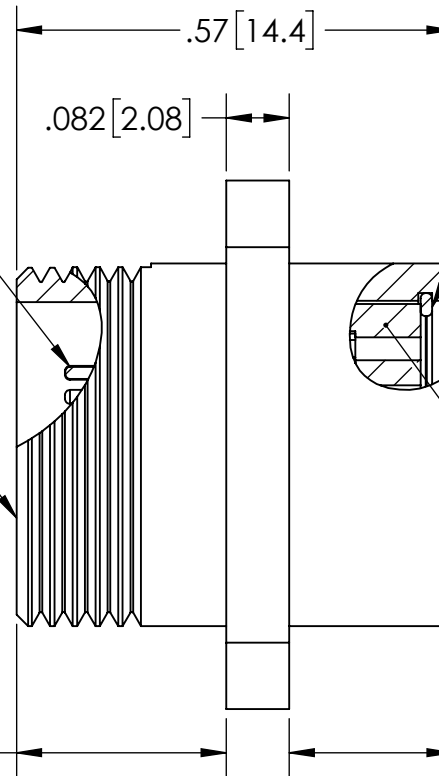

18-8 STN STL
RETAINING RING

PEEK DIELECTRIC
MATERIAL

PERFORMANCE SPECIFICATIONS

VOLTAGE (DWV):	250V DC
CURRENT	2.3 AMPS*
TEMPERATURE (CONTINUOUS):	-55°C TO 150°C
TEMPERATURE (SHORT TERM)	-55°C TO 200°C

*CURRENT FOR A SINGLE PIN (60°C HEAT RISE). DE-RATING MAY BE REQUIRED WHEN RUNNING MULTIPLE CONTACTS AT FULL CURRENT.

PROPRIETARY AND CONFIDENTIAL
THE INFORMATION CONTAINED IN THIS DRAWING IS THE SOLE PROPERTY OF SOLID SEALING TECHNOLOGY. ANY REPRODUCTION IN PART OR AS A WHOLE WITHOUT THE WRITTEN PERMISSION OF SOLID SEALING TECHNOLOGY IS PROHIBITED.

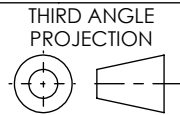

TITLE
19 PIN NON-HERMETIC RECEPTACLE



REV.	APP'D	DATE	SCALE 4:1	DIMENSIONS IN INCHES [mm]	DRAWN	HJ	11/9/2020
A3	HJ	07/19/2021	MSRC0001-11		ENG APPR.	HJ	03/18/2021

PART NO. FA41656 REV. A

WWW.SOLIDSEALING.COM
SALES DWG NO. FA41656SL REV. A3

DIMENSIONS ARE FOR REFERENCE ONLY. UNLESS NOTED, NO TOLERANCES ARE IMPLIED. CONSULT SST TO DISCUSS YOUR SPECIFIC REQUIREMENTS.

3 PINS

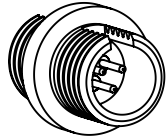

HERMETIC FEEDTHRU
FA42916
(LASER WELD ONLY)

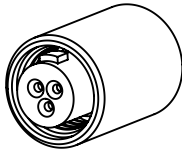

PLUG
FA42930*

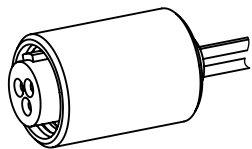

PRE-WIRED PLUG
-KAPTON: FA43039
-PTFE: FA43040

7 PINS

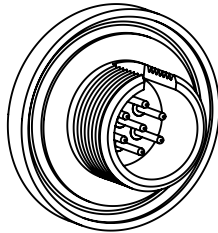

HERMETIC FEEDTHRU
FA41283

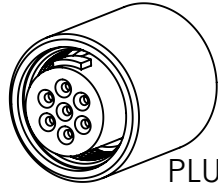

PLUG
FA41289*

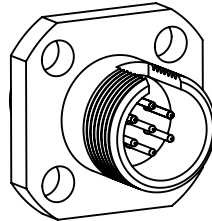

IN-VAC RECEPTACLE
FA42367

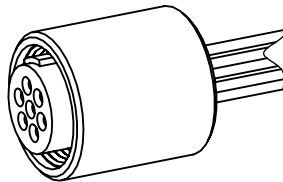

PRE-WIRED PLUG
-KAPTON: FA42314
-PTFE: FA42315

19 PINS

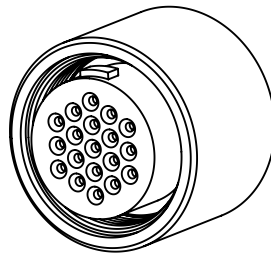

PLUG
FA41232*

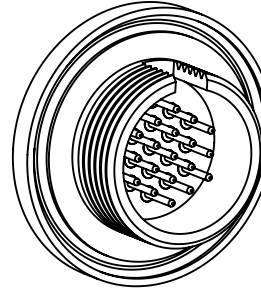

HERMETIC FEEDTHRU
FA41401

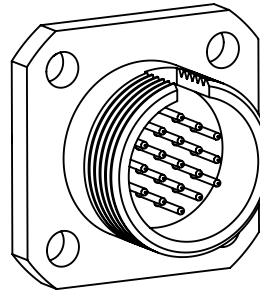

IN-VAC RECEPTACLE
FA41656

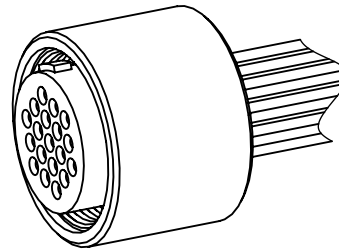

PRE-WIRED PLUG
-KAPTON: FA42316
-PTFE: FA42317

55 PINS

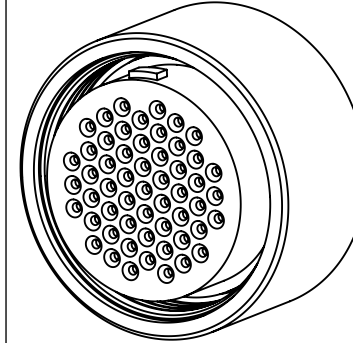

PLUG
FA42256*

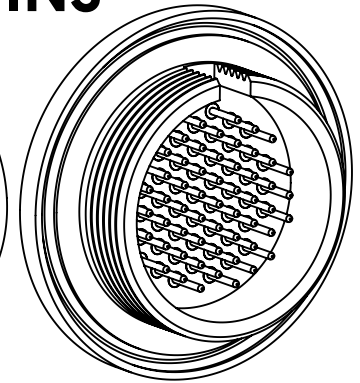

HERMETIC FEEDTHRU
FA42250

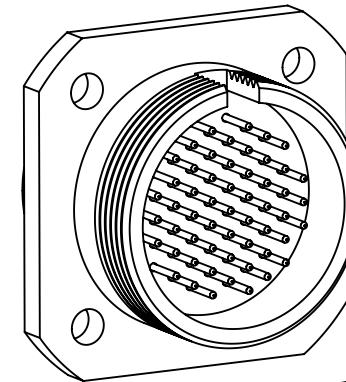

IN-VAC RECEPTACLE
FA42375

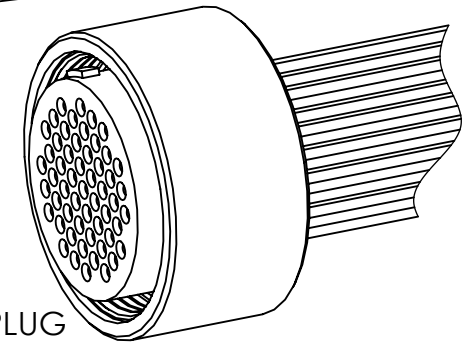

PRE-WIRED PLUG
-KAPTON: FA42318
-PTFE: FA42319

***CONTACTS NOT INCLUDED**

PROPRIETARY AND CONFIDENTIAL

THE INFORMATION CONTAINED IN THIS DRAWING IS THE SOLE PROPERTY OF SOLID SEALING TECHNOLOGY. ANY REPRODUCTION IN PART OR AS A WHOLE WITHOUT THE WRITTEN PERMISSION OF SOLID SEALING TECHNOLOGY IS PROHIBITED.

THIRD ANGLE PROJECTION

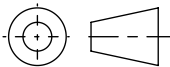

TITLE

MICRO SERIES FAMILY



SOLID SEALING
TECHNOLOGY

REV.	APP'D	DATE	SCALE 2:1	DIMENSIONS IN INCHES [mm]	DRAWN	HJ	04/09/2021
A2	CW	4/21/2022	MPC10735-11		ENG APPR.	HJ	05/03/2021

REV: A2

WWW.SOLIDSEALING.COM

SALES DWG NO. MICRO_SERIES REV. A2

DIMENSIONS ARE FOR REFERENCE ONLY. UNLESS NOTED, NO TOLERANCES ARE IMPLIED. CONSULT SST TO DISCUSS YOUR SPECIFIC REQUIREMENTS.

9 PINS

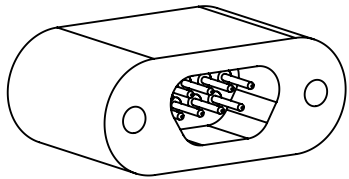

HERMETIC FEEDTHROUGH FA41500

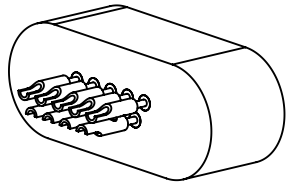

HERMETIC SOLDERCUP FEEDTHROUGH FA42164

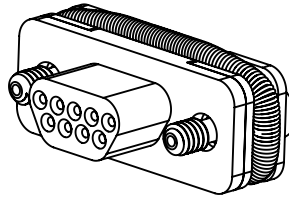

PLUG, GARTER TYPE FA42137

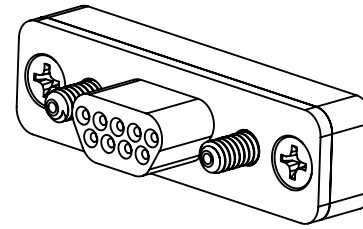

PLUG, SCREW TYPE: FA41506

PRE-WIRED PLUG
-KAPTON: FA42239
-PTFE: FA42419

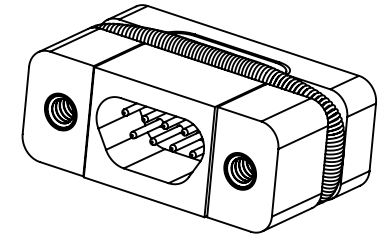

IN-VAC RECEPTACLE FA42394

15 PINS

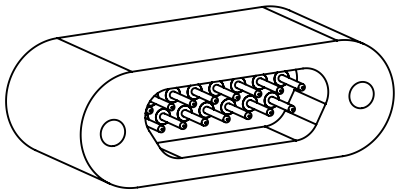

HERMETIC FEEDTHROUGH FA42273

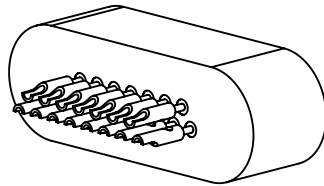

HERMETIC SOLDERCUP FEEDTHROUGH FA42467

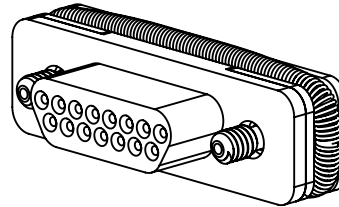

PLUG, GARTER TYPE FA42475

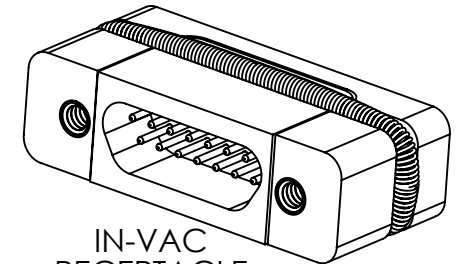

IN-VAC RECEPTACLE FA42488

CONTACTS/WIRE

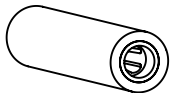

SOCKET CONTACTS
KT41236 (BRASS 125C)
KT41236-02 (TeCu 250C)

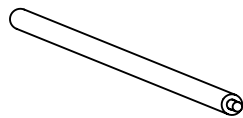

WIRE
KAPTON 48": FA42244
KAPTON 96": FA42245
PTFE 48": FA42246-01/09
PTFE 96": FA42247-01/09



CRIMP TOOL POSITIONER (PIN & SOCKET) FP41731

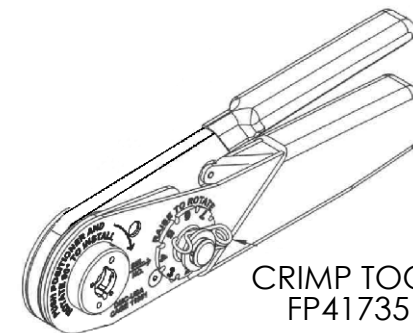

CRIMP TOOL FP41735

PROPRIETARY AND CONFIDENTIAL

THE INFORMATION CONTAINED IN THIS DRAWING IS THE SOLE PROPERTY OF SOLID SEALING TECHNOLOGY. ANY REPRODUCTION IN PART OR AS A WHOLE WITHOUT THE WRITTEN PERMISSION OF SOLID SEALING TECHNOLOGY IS PROHIBITED.

THIRD ANGLE PROJECTION

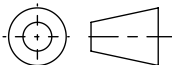

TITLE

MICRO SERIES FAMILY



SOLID SEALING
TECHNOLOGY

REV.	APP'D	DATE	SCALE 2:1	DIMENSIONS IN INCHES [mm]	DRAWN	HJ	04/09/2021
A2	CW	4/21/2022	AHDWR027-41		ENG APPR.	HJ	05/03/2021

REV. A2

WWW.SOLIDSEALING.COM

SALES DWG NO. MICRO_SERIES REV. A2

DIMENSIONS ARE FOR REFERENCE ONLY. UNLESS NOTED, NO TOLERANCES ARE IMPLIED. CONSULT SST TO DISCUSS YOUR SPECIFIC REQUIREMENTS.