

PERFORMANCE SPECIFICATIONS	
.35 dB LOSS PER JUNCTION @ 850 nm TYPICAL, .5dB MAX (@ ROOM TEMPERATURE)	
OPERATING TEMPERATURE: -40°C TO 150°C	
200°C BAKE OUT FOR 1 HOUR	
LEAK RATE <1 X 10E-9 ATM-CC/SEC (He)	

***SEE SHEET 2 FOR MOUNTING DETAILS**

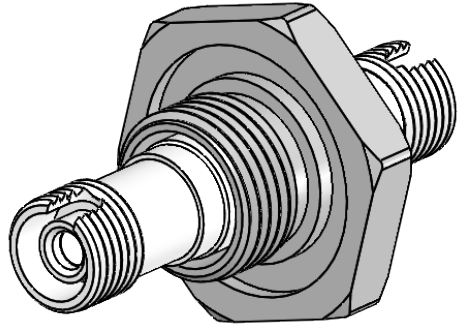

PROPRIETARY AND CONFIDENTIAL THE INFORMATION CONTAINED IN THIS DRAWING IS THE SOLE PROPERTY OF SOLID SEALING TECHNOLOGY. ANY REPRODUCTION IN PART OR AS A WHOLE WITHOUT THE WRITTEN PERMISSION OF SOLID SEALING TECHNOLOGY IS PROHIBITED.				THIRD ANGLE PROJECTION 		TITLE MM FEEDTHROUGH, FC-FC, 50/125			
REV.	APP'D	DATE	SCALE 2:1	DIMENSIONS IN INCHES [mm]	DRAWN	CW	8/27/2021	PART NO. FA42983 REV. A WWW.SOLIDSEALING.COM	
A1	CW	9/7/2021	FOFDN001-33		ENG APPR.	CW	9/7/2021		

DIMENSIONS ARE FOR REFERENCE ONLY. UNLESS NOTED, NO TOLERANCES ARE IMPLIED. CONSULT SST TO DISCUSS YOUR SPECIFIC REQUIREMENTS.

JAM NUT PANEL MOUNTING CONFIGURATION

.093 [2.35] MAX PANEL THICKNESS

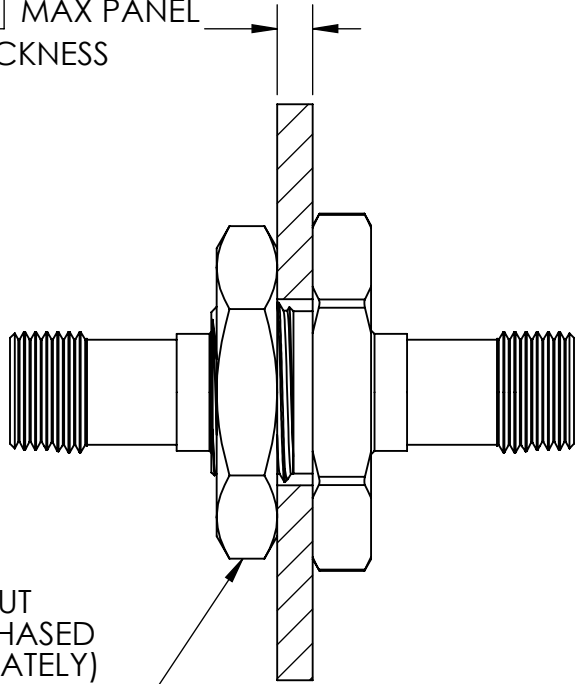

JAM NUT
(PURCHASED SEPARATELY)
SEE FP38340

THREADED PANEL MOUNTING CONFIGURATION

.25 [6.35] TO .75 [19.05]
RECOMMENDED
PANEL THICKNESS

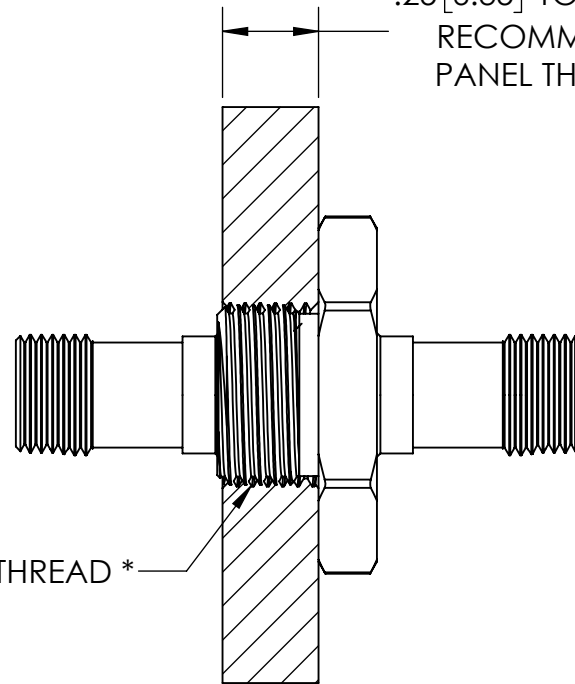

M12 X 1.0 THREAD *

* IF THREAD IS NOT TAPPED THROUGH, ITS DEPTH
MUST BE AT LEAST .264 [6.71]

PROPRIETARY AND CONFIDENTIAL

THE INFORMATION CONTAINED IN THIS DRAWING IS THE SOLE PROPERTY OF SOLID SEALING TECHNOLOGY. ANY REPRODUCTION IN PART OR AS A WHOLE WITHOUT THE WRITTEN PERMISSION OF SOLID SEALING TECHNOLOGY IS PROHIBITED.

THIRD ANGLE PROJECTION

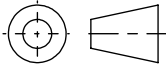

TITLE

MM FEEDTHROUGH, FC-FC, 50/125



SOLID SEALING TECHNOLOGY

REV.	APP'D	DATE	SCALE 2:1	DIMENSIONS IN INCHES [mm]	DRAWN	CW	8/27/2021
A1	CW	9/7/2021	FDN001-33_MOUNTING		ENG APPR.	CW	9/7/2021

PART NO. FA42983 REV. A

WWW.SOLIDSEALING.COM

SALES DWG NO. FA42983SL REV. A1

DIMENSIONS ARE FOR REFERENCE ONLY. UNLESS NOTED, NO TOLERANCES ARE IMPLIED. CONSULT SST TO DISCUSS YOUR SPECIFIC REQUIREMENTS.