

PRECISION ZIRCONIA ALIGNMENT SLEEVE  
 MATES WITH STANDARD FC INTERFACE  
 PRECISION ZIRCONIA FERRULE

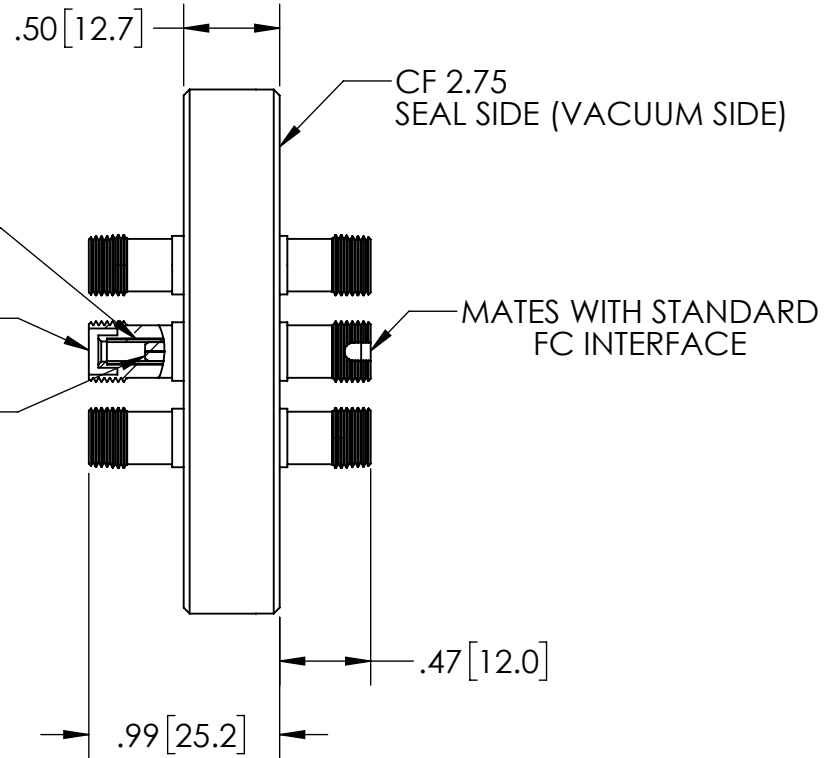
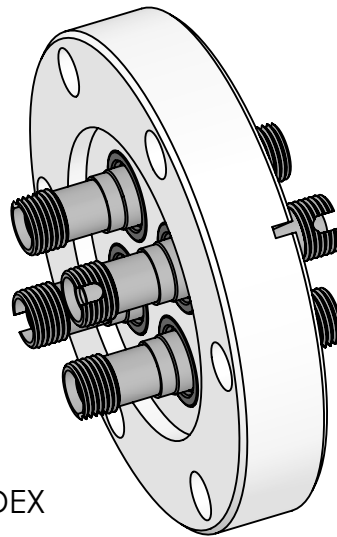

-FIBER: 50/125 $\mu$ m MULTIMODE GRADED INDEX  
 -LEAK RATE <math>< 1 \times 10^{-9}</math> ATM-CC/SEC (He)

PERFORMANCE SPECIFICATIONS
.35 dB LOSS PER JUNCTION @ 850 nm TYPICAL, .5 dB MAX (@ ROOM TEMPERATURE)
OPERATING TEMPERATURE: -40°C TO 150°C 200°C BAKE OUT FOR 1 HOUR

PROPRIETARY AND CONFIDENTIAL THE INFORMATION CONTAINED IN THIS DRAWING IS THE SOLE PROPERTY OF SOLID SEALING TECHNOLOGY. ANY REPRODUCTION IN PART OR AS A WHOLE WITHOUT THE WRITTEN PERMISSION OF SOLID SEALING TECHNOLOGY IS PROHIBITED.				THIRD ANGLE PROJECTION 		TITLE <b>(4) MM FEEDTHRU, FC-FC, 50/125</b>			
REV.	APP'D	DATE	SCALE 1:1	DIMENSIONS IN INCHES [mm]	DRAWN	JF	02/08/2023	PART NO. FA44885 REV. A WWW.SOLIDSEALING.COM	
A1	JF	02/08/2023	FOFDN002-21		ENG APPR.	JF	02/08/2023		

**DIMENSIONS ARE FOR REFERENCE ONLY. UNLESS NOTED, NO TOLERANCES ARE IMPLIED. CONSULT SST TO DISCUSS YOUR SPECIFIC REQUIREMENTS.**