

1- LENGTH OF HELIX IS APPROX. 11.8"

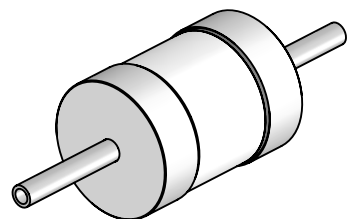
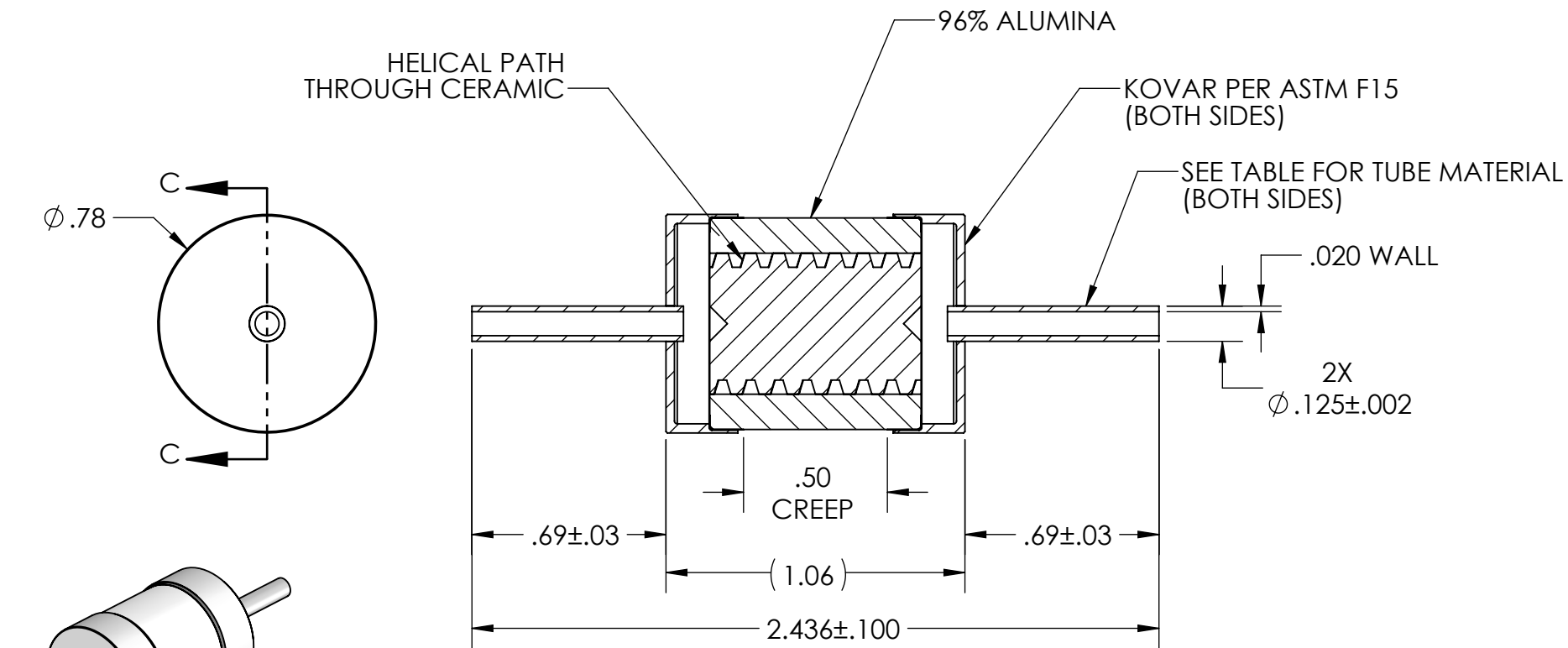

SCALE 1:1

PART NO.	TUBE MATERIAL
FA52004-04	304 STN STL
FA52004-05	INCONEL 625
FA52004-06	KOVAR

PROPRIETARY AND CONFIDENTIAL  
 THE INFORMATION CONTAINED IN THIS DRAWING IS THE SOLE PROPERTY OF SOLID SEALING TECHNOLOGY. ANY REPRODUCTION IN PART OR AS A WHOLE WITHOUT THE WRITTEN PERMISSION OF SOLID SEALING TECHNOLOGY IS PROHIBITED.

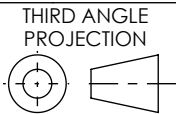

TITLE

BREAK ASSEMBLY



REV.	APP'D	DATE	SCALE 1.75:1	DIMENSIONS IN INCHES [mm]	DRAWN	HJ	10/27/2025
A5	JF	01/21/2026			ENG APPR.	HJ	10/27/2025

PART NO. FA52004 REV. A

WWW.SOLIDSEALING.COM

SALES DWG NO. FA52004SL REV. A5

**DIMENSIONS ARE FOR REFERENCE ONLY. UNLESS NOTED, NO TOLERANCES ARE IMPLIED. CONSULT SST TO DISCUSS YOUR SPECIFIC REQUIREMENTS.**