

GOLD PLATED COPPER ALLOY
CRIMP CONTACTS
ACCEPTS 20-24 AWG WIRE

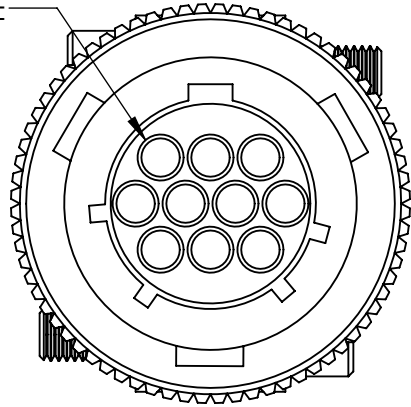

SILICONE RUBBER OR
DIELECTRIC MATERIAL
MEETING MIL-C-26482

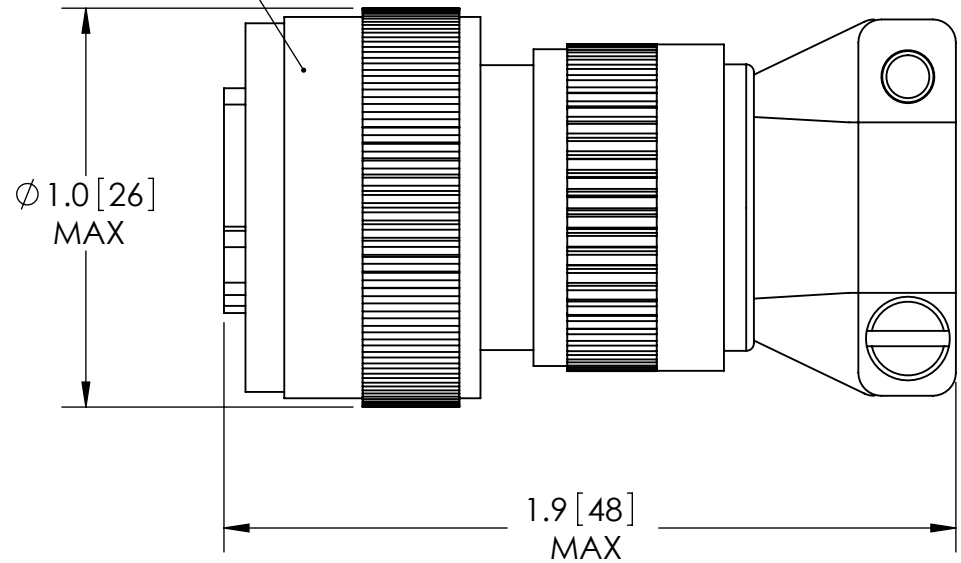

PERFORMANCE SPECIFICATIONS	
VOLTAGE:	1 KV DC
CURRENT:	5 AMPS
TEMPERATURE:	-55°C TO 200°C

REFER TO INSTRUCTION SHEET "NS18065" FOR PLUG ASSEMBLY INSTRUCTIONS.

PROPRIETARY AND CONFIDENTIAL THE INFORMATION CONTAINED IN THIS DRAWING IS THE SOLE PROPERTY OF SOLID SEALING TECHNOLOGY. ANY REPRODUCTION IN PART OR AS A WHOLE WITHOUT THE WRITTEN PERMISSION OF SOLID SEALING TECHNOLOGY IS PROHIBITED.				THIRD ANGLE PROJECTION 		TITLE 10 PIN AIR SIDE PLUG MIL-C-26482			
REV.	APP'D	DATE	SCALE 2:1	DIMENSIONS IN INCHES [mm]	DRAWN	JS	10/5/2007	PART NO. KT14378 REV. A WWW.SOLIDSEALING.COM	
A5	JF	07/02/2021	MSMM0021-11		ENG APPR.	MH	06/05/2008		

DIMENSIONS ARE FOR REFERENCE ONLY. UNLESS NOTED, NO TOLERANCES ARE IMPLIED. CONSULT SST TO DISCUSS YOUR SPECIFIC REQUIREMENTS.

3 PINS

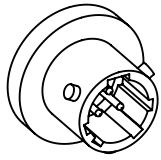

SINGLE ENDED
FEEDTHROUGH:
FA16820

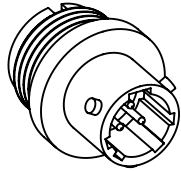

DOUBLE ENDED
FEEDTHROUGH:
FA16822

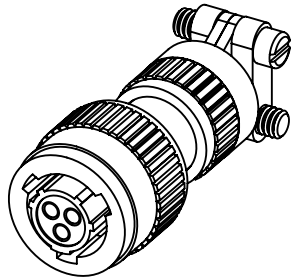

AIR SIDE PLUG (CRIMP): KT18063
AIR SIDE PLUG (SOLDER): FP18062

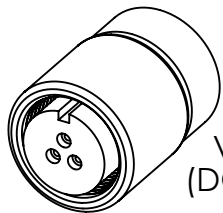

VACUUM SIDE PLUG
(DOUBLE ENDED ONLY):
FA18064

6 PINS

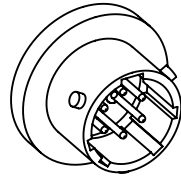

SINGLE ENDED
FEEDTHROUGH:
FA16808

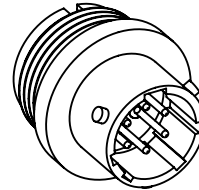

DOUBLE ENDED
FEEDTHROUGH:
FA16809*

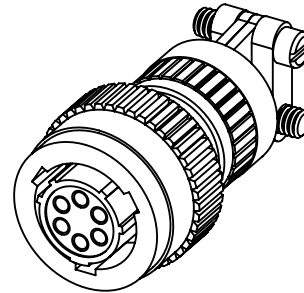

AIR SIDE PLUG (CRIMP): KT18065*
AIR SIDE PLUG (SOLDER): FP18066

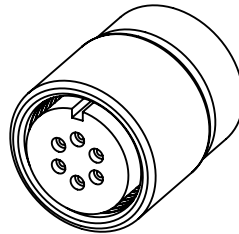

VACUUM SIDE PLUG
(DOUBLE ENDED ONLY):
FA18067*

*THERMOCOUPLE TYPE K
OPTION AVAILABLE

10 PINS

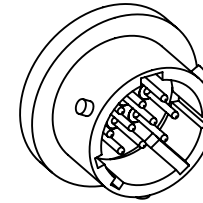

SINGLE ENDED
FEEDTHROUGH:
FA13003

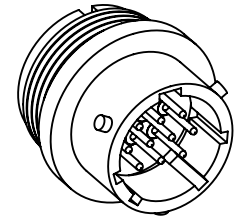

DOUBLE ENDED
FEEDTHROUGH:
FA12933*

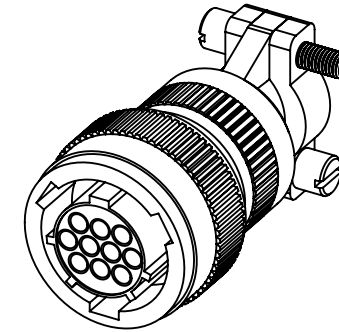

AIR SIDE PLUG (CRIMP): KT14378*
AIR SIDE PLUG (SOLDER): FP14900

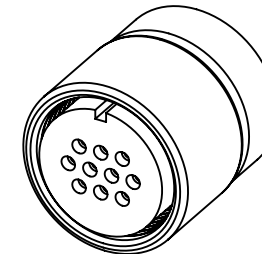

VACUUM SIDE PLUG
(DOUBLE ENDED ONLY):
FA13461*

PROPRIETARY AND CONFIDENTIAL

THE INFORMATION CONTAINED IN THIS DRAWING IS THE
SOLE PROPERTY OF SOLID SEALING TECHNOLOGY. ANY
REPRODUCTION IN PART OR AS A WHOLE WITHOUT THE WRITTEN
PERMISSION OF SOLID SEALING TECHNOLOGY IS PROHIBITED.

THIRD ANGLE
PROJECTION

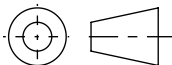

TITLE

26482 SERIES FAMILY



SOLID SEALING
TECHNOLOGY

REV.	APP'D	DATE	SCALE 1:1	DIMENSIONS IN INCHES [mm]	DRAWN	CW	8/19/2021
A2	JF	01/22/2025	MPC10163-11		ENG APPR.	JF	1/27/2022

REV: A2

WWW.SOLIDSEALING.COM

SALES DWG NO. 26482_SERIES REV. A2

DIMENSIONS ARE FOR REFERENCE ONLY. UNLESS NOTED, NO TOLERANCES ARE IMPLIED. CONSULT SST TO DISCUSS YOUR SPECIFIC REQUIREMENTS.

19 PINS

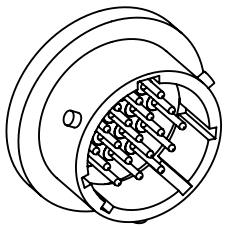

SINGLE ENDED
FEEDTHROUGH:
FA13002

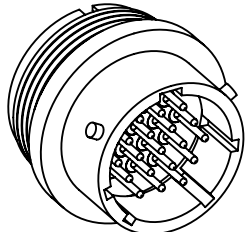

DOUBLE ENDED
FEEDTHROUGH:
FA12932*

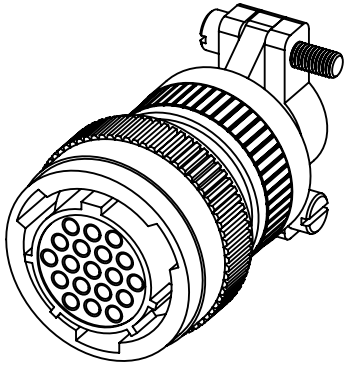

AIR SIDE PLUG (CRIMP): KT14379*
AIR SIDE PLUG (SOLDER): FP14901

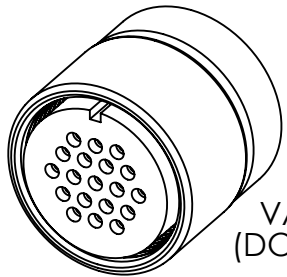

VACUUM SIDE PLUG
(DOUBLE ENDED ONLY):
FA13462*

32 PINS

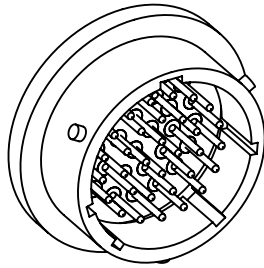

SINGLE ENDED
FEEDTHROUGH:
FA13001

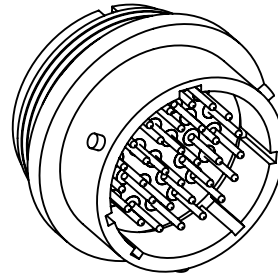

DOUBLE ENDED
FEEDTHROUGH:
FA12931*

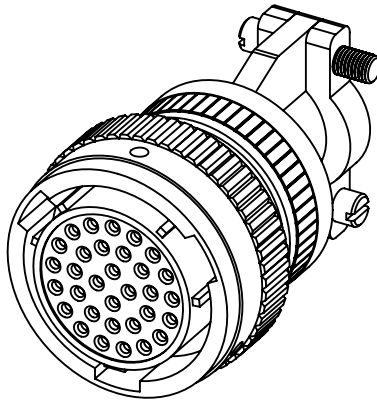

AIR SIDE PLUG (CRIMP): KT14380*
AIR SIDE PLUG (SOLDER): FP14902

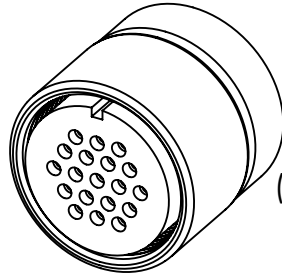

VACUUM SIDE PLUG
(DOUBLE ENDED ONLY):
FA13463*

*THERMOCOUPLE TYPE K
OPTION AVAILABLE

41 PINS

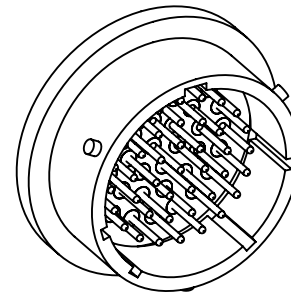

SINGLE ENDED
FEEDTHROUGH:
FA12998

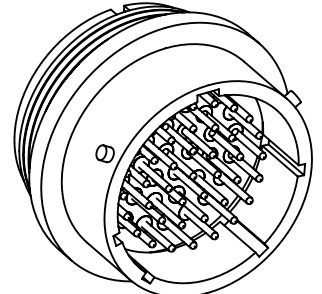

DOUBLE ENDED
FEEDTHROUGH:
FA12930

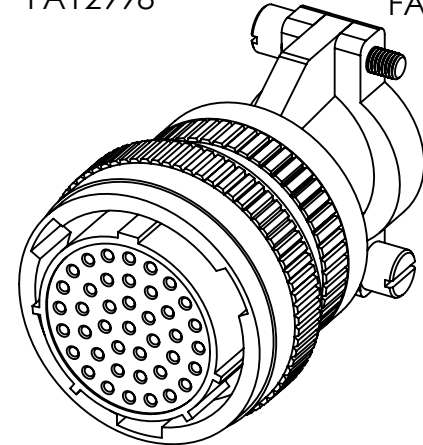

AIR SIDE PLUG (CRIMP): KT14381
AIR SIDE PLUG (SOLDER): FP14903

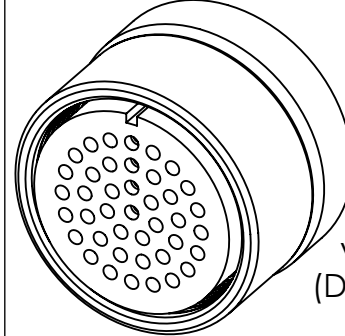

VACUUM SIDE PLUG
(DOUBLE ENDED ONLY):
FA13464

PROPRIETARY AND CONFIDENTIAL

THE INFORMATION CONTAINED IN THIS DRAWING IS THE
SOLE PROPERTY OF SOLID SEALING TECHNOLOGY. ANY
REPRODUCTION IN PART OR AS A WHOLE WITHOUT THE WRITTEN
PERMISSION OF SOLID SEALING TECHNOLOGY IS PROHIBITED.

THIRD ANGLE
PROJECTION

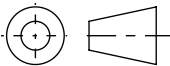

TITLE

26482 SERIES FAMILY



SOLID SEALING
TECHNOLOGY

REV.	APP'D	DATE	SCALE 1:1	DIMENSIONS IN INCHES [mm]	DRAWN	CW	8/19/2021
A2	JF	01/22/2025	MPC0054-02		ENG APPR.	JF	1/27/2022

REV: A2

WWW.SOLIDSEALING.COM

SALES DWG NO. 26482_SERIES REV. A2

DIMENSIONS ARE FOR REFERENCE ONLY. UNLESS NOTED, NO TOLERANCES ARE IMPLIED. CONSULT SST TO DISCUSS YOUR SPECIFIC REQUIREMENTS.

CONTACTS/WIRE/CRIMP TOOL/LOCATOR

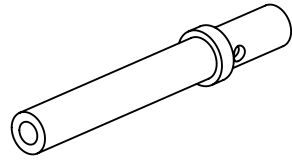

CRIMP CONTACTS
 KT13353 (COPPER ALLOY)
 KT13353-02 (CHROMEL)**
 KT13353-03 (ALUMEL)**
 KT13353-11 (COPPER ALLOY,
 NO COLOR BANDS)

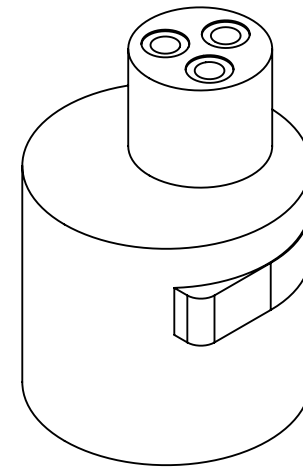

LOCATOR
 FP44441
 (USED WITH FP44440)

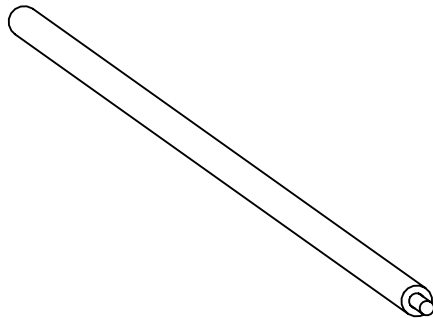

22 AWG WIRE
 KAPTON
 (CUSTOM LENGTHS AVAILABLE)
 FA15065

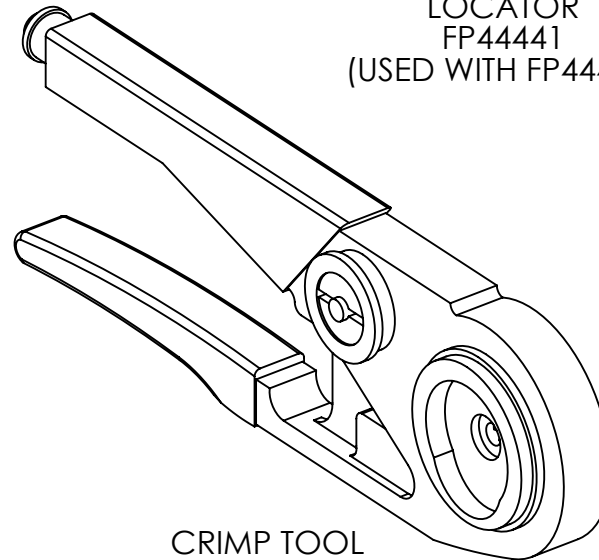

CRIMP TOOL
 FP44440

**THERMOCOUPLE TYPE K CRIMP CONTACTS

PROPRIETARY AND CONFIDENTIAL THE INFORMATION CONTAINED IN THIS DRAWING IS THE SOLE PROPERTY OF SOLID SEALING TECHNOLOGY. ANY REPRODUCTION IN PART OR AS A WHOLE WITHOUT THE WRITTEN PERMISSION OF SOLID SEALING TECHNOLOGY IS PROHIBITED.				THIRD ANGLE PROJECTION 		TITLE 26482 SERIES FAMILY			
REV.	APP'D	DATE	SCALE 1:1	DIMENSIONS IN INCHES [mm]	DRAWN	CW	8/19/2021	REV: A2	WWW.SOLIDSEALING.COM
A2	JF	01/22/2025	ACDCN010-1ST	ENG APPR.	JF	1/27/2022	SALES DWG NO. 26482_SERIES REV. A2		

DIMENSIONS ARE FOR REFERENCE ONLY. UNLESS NOTED, NO TOLERANCES ARE IMPLIED. CONSULT SST TO DISCUSS YOUR SPECIFIC REQUIREMENTS.