

PLUG BODY: MOLDED SILICONE RUBBER

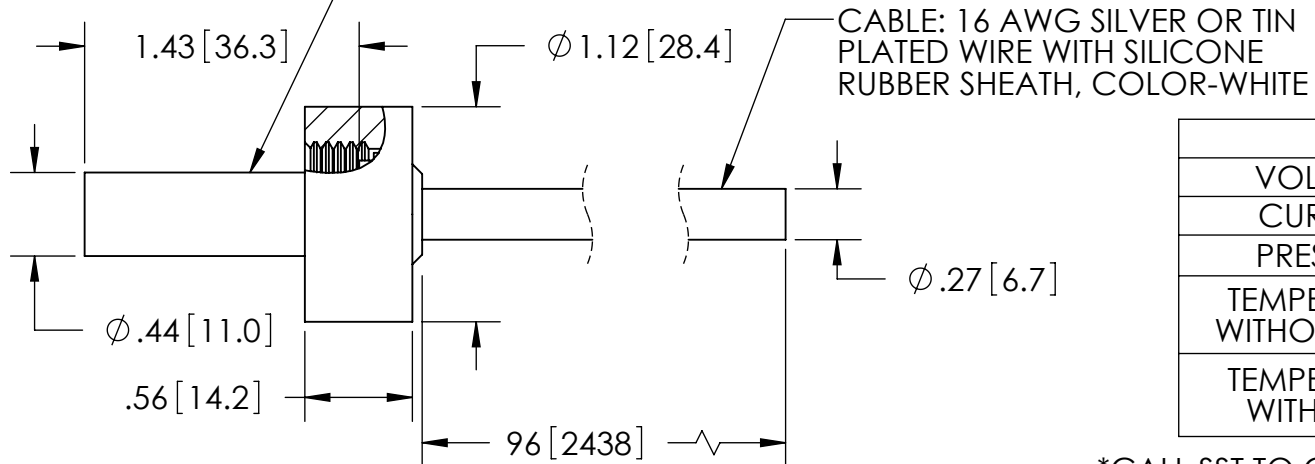

AIR SIDE PLUG/CABLE ASSEMBLY INCLUDED

RATINGS	
VOLTAGE:	30KV DC
CURRENT:	10 AMPS
PRESSURE:	400 PSIG @ 20°C
TEMPERATURE WITHOUT PLUG:	-80°C TO 450°C*
TEMPERATURE WITH PLUG:	-55°C TO 125°C

\*CALL SST TO CONFIRM LOWER TEMPERATURE USE

[WWW.SOLIDSEALING.COM](http://WWW.SOLIDSEALING.COM)



SOLID SEALING TECHNOLOGY, INC.

SALES DWG NO. KT22001SL REV. C2

PROPRIETARY AND CONFIDENTIAL

THE INFORMATION CONTAINED IN THIS DRAWING IS THE SOLE PROPERTY OF SOLID SEALING TECHNOLOGY. ANY REPRODUCTION IN PART OR AS A WHOLE WITHOUT THE WRITTEN PERMISSION OF SOLID SEALING TECHNOLOGY IS PROHIBITED.

THIRD ANGLE PROJECTION

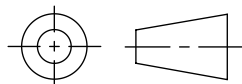

TITLE:

30KV CONNECTOR

REV.	APP'D	DATE	SCALE 1:1	DIMENSIONS IN INCHES [mm]	DRAWN	JS	01/07/2011
C2	JF	04/05/2019	FTCL0147-13		ENG APPR.	JS	12/16/2013

PART NO. KT22001 REV. C

**DIMENSIONS ARE FOR REFERENCE ONLY. UNLESS NOTED, NO TOLERANCES ARE IMPLIED. CONSULT SST TO DISCUSS YOUR SPECIFIC REQUIREMENTS.**