

- 1) STRIP OUTER JACKET TO 2.0". STRIP THE BRAID AND FOIL SO THAT THEY WON'T CONTACT THE BACKSHELL WHEN ASSEMBLED.
- 2) STRIP THE TEFLON INSULATION TO .30". THIS MAY BE DONE AFTER THE CABLE IS INSERTED THROUGH THE PLUG BACK.

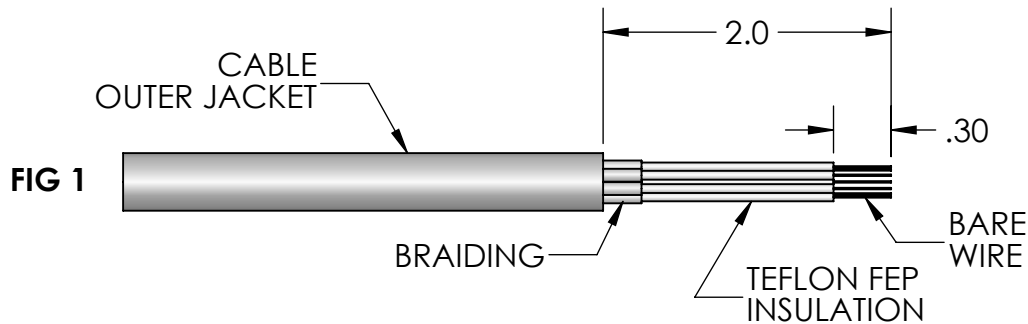

- 7) SELECT THE 7mm STRAIN RELIEF, ATTACH TO CABLE. MOUNT PLUG, CABLE ASSEMBLY AND HEX SCREWS INTO ONE HALF OF BACKSHELL. BACKSHELL LIP FITS INTO GROOVE OF PLUG BACK. MAKE SURE THE BRAID DOES NOT CONTACT THE BACKSHELL.
- 8) ASSEMBLE THE OTHER HALF OF BACK SHELL, AND TIGHTEN BACKSHELL SCREWS

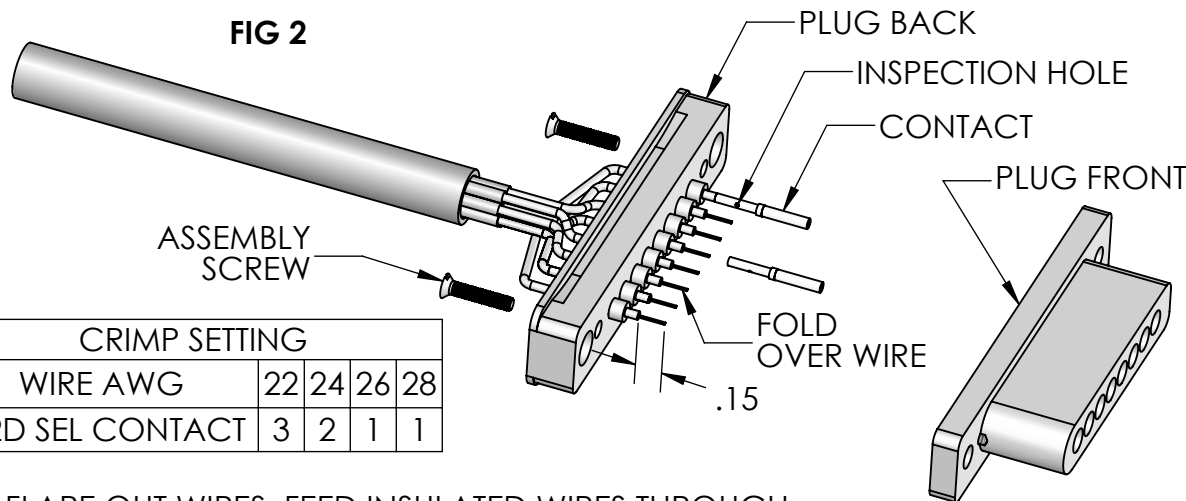

CRIMP SETTING				
WIRE AWG	22	24	26	28
-22D SEL CONTACT	3	2	1	1

- 3) FLARE OUT WIRES, FEED INSULATED WIRES THROUGH PLUG BACK. STRIP INSULATION IF NOT DONE YET.
- 4) FOLD OVER WIRES, FULLY INSERT INTO CONTACTS. WIRES SHOULD BE VISIBLE IN INSPECTION HOLES OF CONTACTS, AND INSULATION SHOULD BE AGAINST THE BACK OF THE CONTACTS.
- 5) CRIMP CONTACTS ONTO WIRES USING CRIMP TOOL SST P/N FP31723 AND LOCATOR FP32470. CENTER CRIMP BETWEEN END OF CONTACT AND INSPECTION HOLE.
- 6) INSERT CONTACTS INTO PLUG BACK AND PLUG FRONT. INSERT ASSEMBLY SCREWS THROUGH PLUG BACK INTO PLUG FRONT AND TIGHTEN.

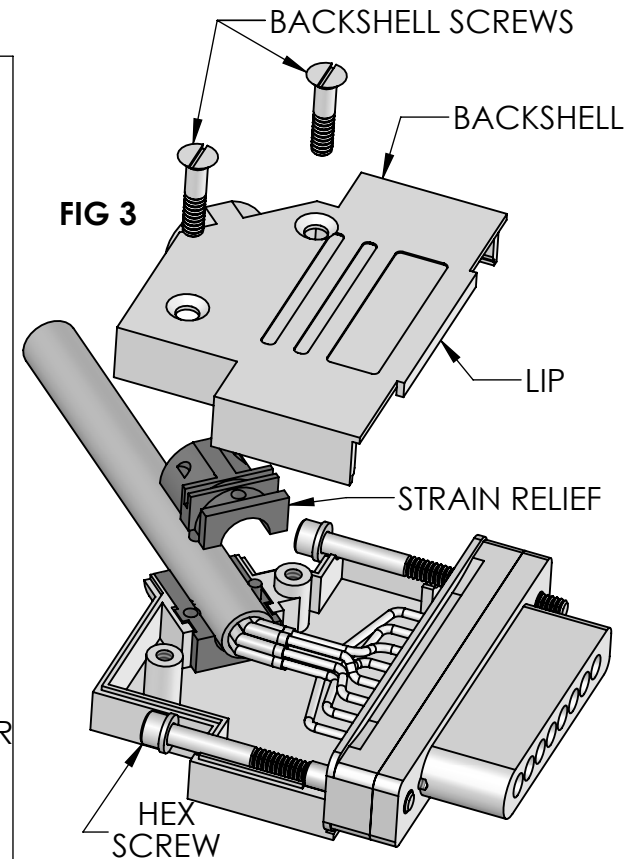

PROPRIETARY AND CONFIDENTIAL  
THE INFORMATION CONTAINED IN THIS DRAWING IS THE SOLE PROPERTY OF SOLID SEALING TECHNOLOGY. ANY REPRODUCTION IN PART OR AS A WHOLE WITHOUT THE WRITTEN PERMISSION OF SOLID SEALING TECHNOLOGY IS PROHIBITED.

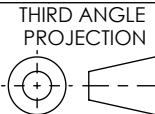

TITLE: **INSTRUCTION SHEET**  
**8 PIN PLUG AND BACKSHELL**



REV.	APP'D	DATE	SCALE 1:1	DIMENSIONS IN INCHES [mm]	DRAWN	MH	5/28/2014	NUMBER:
B	JF	06/10/2021	NS28193-13		ENG APPR.	OG	09/09/2014	

**NS28193**

REV: **B**

SHEET 1 OF 1